

INSTRUCTION MANUAL

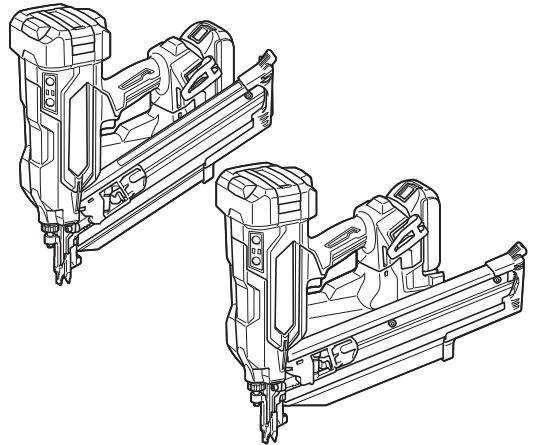

Cordless Framing Nailer

DBN900
DBN901



Read before use.

SPECIFICATIONS

Model:	DBN900	DBN901
Figure of nail head	Clipped	Round
Nail length	50 mm - 90 mm	
Shank diameter	ø2.9 mm - ø3.3 mm	ø2.9 mm - ø3.8 mm
Magazine capacity	51 - 61 nails (1 strip + 11 - 21 nails)	40 - 44 nails (1 strip + 15 - 19 nails)
Nail collation angle	30° - 34°	21°
Dimensions (L x W x H) ¹	327 mm x 186 mm x 359 mm	389 mm x 189 mm x 359 mm
Rated voltage	D.C. 18 V	
Net weight	*** - *** kg	

¹ without hooks

- Due to our continuing program of research and development, the specifications herein are subject to change without notice.
- Specifications may differ from country to country.
- The weight may differ depending on the attachment(s), including the battery cartridge. The lightest and heaviest combination are shown in the table.

Applicable battery cartridge and charger





Battery cartridge	BL1820B / BL1830B / BL1840B / BL1850B / BL1860B
Charger	DC18RC / DC18RD / DC18RE / DC18SD / DC18SE / DC18SF / DC18SH / DC18WC

- Some of the battery cartridges and chargers listed above may not be available depending on your region of residence.

⚠ WARNING: Only use the battery cartridges and chargers listed above. Use of any other battery cartridges and chargers may cause injury and/or fire.

Symbols

The followings show the symbols which may be used for the equipment. Be sure that you understand their meaning before use.

	Read instruction manual.
	Wear eye protection.
	Wear ear protection.
	Do not use on scaffoldings, ladders.
	Keep fingers away from trigger when not driving fasteners to avoid accidental firing.



Only for EU countries

Due to the presence of hazardous components in the equipment, waste electrical and electronic equipment, accumulators and batteries may have a negative impact on the environment and human health. Do not dispose of electrical and electronic appliances or batteries with household waste!

In accordance with the European Directive on waste electrical and electronic equipment and on accumulators and batteries, as well as their adaptation to national law, waste electrical equipment, batteries and accumulators should be stored separately and delivered to a separate collection point for municipal waste, operating in accordance with the regulations on environmental protection.

This is indicated by the symbol of the crossed-out wheeled bin placed on the equipment.

Intended use

The tool is intended for the preliminary interior work such as fixing floor joists or common rafters and framing work in 2" x 4" housing.

Noise

The typical A-weighted noise level determined according to EN60745-2-16:

Sound pressure level (L_{pA}) : *** dB (A)

Sound power level (L_{WA}) : *** dB (A)

Uncertainty (K) : *** dB (A)

⚠ WARNING: Wear ear protection.

Vibration

The vibration total value determined according to EN60745-2-16:

Vibration emission (a_{hv}) : 2.5 m/s² or less

Uncertainty (K) : 1.5 m/s²

NOTE: The declared vibration total value(s) has been measured in accordance with a standard test method and may be used for comparing one tool with another.

NOTE: The declared vibration total value(s) may also be used in a preliminary assessment of exposure.

⚠ WARNING: The vibration emission during actual use of the power tool can differ from the declared value(s) depending on the ways in which the tool is used especially what kind of workpiece is processed.

⚠ WARNING: Be sure to identify safety measures to protect the operator that are based on an estimation of exposure in the actual conditions of use (taking account of all parts of the operating cycle such as the times when the tool is switched off and when it is running idle in addition to the trigger time).

Declarations of Conformity

For European countries only

The Declarations of conformity are included in Annex A to this instruction manual.

SAFETY WARNINGS

General power tool safety warnings

⚠ WARNING Read all safety warnings, instructions, illustrations and specifications provided with this power tool. Failure to follow all instructions listed below may result in electric shock, fire and/or serious injury.

Save all warnings and instructions for future reference.

The term "power tool" in the warnings refers to your mains-operated (corded) power tool or battery-operated (cordless) power tool.

Work area safety

1. **Keep work area clean and well lit.** Cluttered or dark areas invite accidents.
2. **Do not operate power tools in explosive atmospheres, such as in the presence of flammable liquids, gases or dust.** Power tools create sparks which may ignite the dust or fumes.
3. **Keep children and bystanders away while operating a power tool.** Distractions can cause

you to lose control.

Electrical safety

1. **Power tool plugs must match the outlet. Never modify the plug in any way. Do not use any adapter plugs with earthed (grounded) power tools.** Unmodified plugs and matching outlets will reduce risk of electric shock.
2. **Avoid body contact with earthed or grounded surfaces, such as pipes, radiators, ranges and refrigerators.** There is an increased risk of electric shock if your body is earthed or grounded.
3. **Do not expose power tools to rain or wet conditions.** Water entering a power tool will increase the risk of electric shock.
4. **Do not abuse the cord. Never use the cord for carrying, pulling or unplugging the power tool. Keep cord away from heat, oil, sharp edges or moving parts.** Damaged or entangled cords increase the risk of electric shock.
5. **When operating a power tool outdoors, use an extension cord suitable for outdoor use.** Use of a cord suitable for outdoor use reduces the risk of electric shock.
6. **If operating a power tool in a damp location is unavoidable, use a residual current device (RCD) protected supply.** Use of an RCD reduces the risk of electric shock.
7. **Power tools can produce electromagnetic fields (EMF) that are not harmful to the user.** However, users of pacemakers and other similar medical devices should contact the maker of their device and/or doctor for advice before operating this power tool.

Personal safety

1. **Stay alert, watch what you are doing and use common sense when operating a power tool. Do not use a power tool while you are tired or under the influence of drugs, alcohol or medication.** A moment of inattention while operating power tools may result in serious personal injury.
2. **Use personal protective equipment. Always wear eye protection.** Protective equipment such as a dust mask, non-skid safety shoes, hard hat or hearing protection used for appropriate conditions will reduce personal injuries.
3. **Prevent unintentional starting. Ensure the switch is in the off-position before connecting to power source and/or battery pack, picking up or carrying the tool.** Carrying power tools with your finger on the switch or energising power tools that have the switch on invites accidents.
4. **Remove any adjusting key or wrench before turning the power tool on.** A wrench or a key left attached to a rotating part of the power tool may result in personal injury.
5. **Do not overreach. Keep proper footing and balance at all times.** This enables better control of the power tool in unexpected situations.
6. **Dress properly. Do not wear loose clothing or jewellery. Keep your hair and clothing away from moving parts.** Loose clothes, jewellery or long hair can be caught in moving parts.
7. **If devices are provided for the connection of dust extraction and collection facilities, ensure**

these are connected and properly used. Use of dust collection can reduce dust-related hazards.

8. **Do not let familiarity gained from frequent use of tools allow you to become complacent and ignore tool safety principles.** A careless action can cause severe injury within a fraction of a second.
9. **Always wear protective goggles to protect your eyes from injury when using power tools.** The goggles must comply with ANSI Z87.1 in the USA, EN 166 in Europe, or AS/NZS 1336 in Australia/New Zealand. In Australia/New Zealand, it is legally required to wear a face shield to protect your face, too.

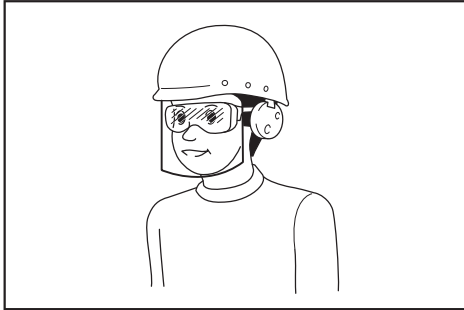

It is an employer's responsibility to enforce the use of appropriate safety protective equipments by the tool operators and by other persons in the immediate working area.

Power tool use and care

1. **Do not force the power tool. Use the correct power tool for your application.** The correct power tool will do the job better and safer at the rate for which it was designed.
2. **Do not use the power tool if the switch does not turn it on and off.** Any power tool that cannot be controlled with the switch is dangerous and must be repaired.
3. **Disconnect the plug from the power source and/or remove the battery pack, if detachable, from the power tool before making any adjustments, changing accessories, or storing power tools.** Such preventive safety measures reduce the risk of starting the power tool accidentally.
4. **Store idle power tools out of the reach of children and do not allow persons unfamiliar with the power tool or these instructions to operate the power tool.** Power tools are dangerous in the hands of untrained users.
5. **Maintain power tools and accessories. Check for misalignment or binding of moving parts, breakage of parts and any other condition that may affect the power tool's operation. If damaged, have the power tool repaired before use.** Many accidents are caused by poorly maintained power tools.
6. **Keep cutting tools sharp and clean.** Properly maintained cutting tools with sharp cutting edges are less likely to bind and are easier to control.
7. **Use the power tool, accessories and tool bits etc. in accordance with these instructions,**

taking into account the working conditions and the work to be performed. Use of the power tool for operations different from those intended could result in a hazardous situation.

8. **Keep handles and grasping surfaces dry, clean and free from oil and grease.** Slippery handles and grasping surfaces do not allow for safe handling and control of the tool in unexpected situations.
9. **When using the tool, do not wear cloth work gloves which may be entangled.** The entanglement of cloth work gloves in the moving parts may result in personal injury.

Battery tool use and care

1. **Recharge only with the charger specified by the manufacturer.** A charger that is suitable for one type of battery pack may create a risk of fire when used with another battery pack.
2. **Use power tools only with specifically designated battery packs.** Use of any other battery packs may create a risk of injury and fire.
3. **When battery pack is not in use, keep it away from other metal objects, like paper clips, coins, keys, nails, screws or other small metal objects, that can make a connection from one terminal to another.** Shorting the battery terminals together may cause burns or a fire.
4. **Under abusive conditions, liquid may be ejected from the battery; avoid contact.** If contact accidentally occurs, flush with water. If liquid contacts eyes, additionally seek medical help. Liquid ejected from the battery may cause irritation or burns.
5. **Do not use a battery pack or tool that is damaged or modified.** Damaged or modified batteries may exhibit unpredictable behaviour resulting in fire, explosion or risk of injury.
6. **Do not expose a battery pack or tool to fire or excessive temperature.** Exposure to fire or temperature above 130 °C may cause explosion.
7. **Follow all charging instructions and do not charge the battery pack or tool outside the temperature range specified in the instructions.** Charging improperly or at temperatures outside the specified range may damage the battery and increase the risk of fire.

Service

1. **Have your power tool serviced by a qualified repair person using only identical replacement parts.** This will ensure that the safety of the power tool is maintained.
2. **Never service damaged battery packs.** Service of battery packs should only be performed by the manufacturer or authorized service providers.
3. **Follow instruction for lubricating and changing accessories.**

Cordless nailer safety warnings

1. **Always assume that the tool contains fasteners.** Careless handling of the nailer can result in unexpected firing of fasteners and personal injury.
2. **Do not point the tool towards yourself or anyone nearby.** Unexpected triggering will discharge the fastener causing an injury.

3. **Do not actuate the tool unless the tool is placed firmly against the workpiece.** If the tool is not in contact with the workpiece, the fastener may be deflected away from your target.
4. **Disconnect the tool from the power source when the fastener jams in the tool.** While removing a jammed fastener, the nailer may be accidentally activated if it is plugged in.
5. **Use caution while removing a jammed fastener.** The mechanism may be under compression and the fastener may be forcefully discharged while attempting to free a jammed condition.
6. **Do not use this nailer for fastening electrical cables.** It is not designed for electric cable installation and may damage the insulation of electric cables thereby causing electric shock or fire hazards.
7. **Always wear safety glasses to protect your eyes from dust or fastener injury.**
8. **Keep hands and feet away from the ejection port area.**
9. **Follow instruction for lubricating and changing accessories.**
10. **Always remove the battery cartridge before loading the fasteners, adjustment, inspection, maintenance or after operation is over.**
11. **Make sure no one is nearby before operation. Never attempt to drive fasteners from both the inside and outside of wall at the same time. Fasteners may rip through and/or fly off, presenting a grave danger.**
12. **Watch your footing and maintain your balance with the tool. Make sure there is no one below when working in high locations.**
13. **Never use fastener driving tools marked with the symbol "Do not use on scaffoldings, ladders" for specific application for example:**
 - when changing one driving location to another involves the use of scaffoldings, stairs, ladders, or ladder alike constructions, e.g. roof laths;
 - closing boxes or crates;
 - fitting transportation safety systems e.g. on vehicles and wagons.
14. **Check walls, ceilings, floors, roofing and the like carefully to avoid possible electrical shock, gas leakage, explosions, etc. caused by stapling into live wires, conduits or gas pipes.**
15. **Use only fasteners specified in this manual. The use of any other fasteners may cause malfunction of the tool.**
16. **Do not tamper with the tool or attempt to use it for other than driving fasteners.**
17. **Do not operate the tool without fasteners. It shortens the service life of the tool.**
18. **Stop driving operations immediately if you notice something wrong or out of the ordinary with the tool.**
19. **Never fasten into any materials which may allow the fastener to puncture and fly through as a projectile.**
20. **Never actuate the switch trigger and contact element at the same time until you are prepared to fasten workpieces. Allow the**

workpiece to depress the contact element. Never defeat its purpose by securing the contact element back or by depressing it by hand.

21. **Never tamper with the contact element. Check the contact element frequently for proper operations.**
22. **Always remove fasteners from the tool when not in use.**
23. **Avoid placing magnets or similar magnetic device too close to the tool. It may affect the magnetic sensor in the tool.**

SAVE THESE INSTRUCTIONS.

⚠WARNING: DO NOT let comfort or familiarity with product (gained from repeated use) replace strict adherence to safety rules for the subject product. MISUSE or failure to follow the safety rules stated in this instruction manual may cause serious personal injury.

Important safety instructions for battery cartridge

1. **Before using battery cartridge, read all instructions and cautionary markings on (1) battery charger, (2) battery, and (3) product using battery.**
2. **Do not disassemble or tamper with the battery cartridge.** It may result in a fire, excessive heat, or explosion.
3. **If operating time has become excessively shorter, stop operating immediately. It may result in a risk of overheating, possible burns and even an explosion.**
4. **If electrolyte gets into your eyes, rinse them out with clear water and seek medical attention right away. It may result in loss of your eyesight.**
5. **Do not short the battery cartridge:**
 - (1) **Do not touch the terminals with any conductive material.**
 - (2) **Avoid storing battery cartridge in a container with other metal objects such as nails, coins, etc.**
 - (3) **Do not expose battery cartridge to water or rain.**

A battery short can cause a large current flow, overheating, possible burns and even a breakdown.
6. **Do not store and use the tool and battery cartridge in locations where the temperature may reach or exceed 50 °C (122 °F).**
7. **Do not incinerate the battery cartridge even if it is severely damaged or is completely worn out. The battery cartridge can explode in a fire.**
8. **Do not nail, cut, crush, throw, drop the battery cartridge, or hit against a hard object to the battery cartridge.** Such conduct may result in a fire, excessive heat, or explosion.
9. **Do not use a damaged battery.**
10. **The contained lithium-ion batteries are subject to the Dangerous Goods Legislation requirements.**

For commercial transports e.g. by third parties,

forwarding agents, special requirement on packaging and labeling must be observed. For preparation of the item being shipped, consulting an expert for hazardous material is required. Please also observe possibly more detailed national regulations.

Tape or mask off open contacts and pack up the battery in such a manner that it cannot move around in the packaging.

11. **When disposing the battery cartridge, remove it from the tool and dispose of it in a safe place. Follow your local regulations relating to disposal of battery.**
12. **Use the batteries only with the products specified by Makita.** Installing the batteries to non-compliant products may result in a fire, excessive heat, explosion, or leak of electrolyte.
13. **If the tool is not used for a long period of time, the battery must be removed from the tool.**
14. **During and after use, the battery cartridge may take on heat which can cause burns or low temperature burns. Pay attention to the handling of hot battery cartridges.**
15. **Do not touch the terminal of the tool immediately after use as it may get hot enough to cause burns.**
16. **Do not allow chips, dust, or soil stuck into the terminals, holes, and grooves of the battery cartridge.** It may cause heating, catching fire, burst and malfunction of the tool or battery cartridge, resulting in burns or personal injury.
17. **Unless the tool supports the use near high-voltage electrical power lines, do not use the battery cartridge near high-voltage electrical power lines.** It may result in a malfunction or breakdown of the tool or battery cartridge.
18. **Keep the battery away from children.**

SAVE THESE INSTRUCTIONS.

CAUTION: Only use genuine Makita batteries. Use of non-genuine Makita batteries, or batteries that have been altered, may result in the battery bursting causing fires, personal injury and damage. It will also void the Makita warranty for the Makita tool and charger.

Tips for maintaining maximum battery life

1. **Charge the battery cartridge before completely discharged. Always stop tool operation and charge the battery cartridge when you notice less tool power.**
2. **Never recharge a fully charged battery cartridge. Overcharging shortens the battery service life.**
3. **Charge the battery cartridge with room temperature at 10 °C - 40 °C (50 °F - 104 °F). Let a hot battery cartridge cool down before charging it.**
4. **When not using the battery cartridge, remove it from the tool or the charger.**
5. **Charge the battery cartridge if you do not use it for a long period (more than six months).**

FUNCTIONAL DESCRIPTION

CAUTION: Always be sure that the tool is switched off and the battery cartridge is removed before adjusting or checking function on the tool.

Installing or removing battery cartridge

CAUTION: Always switch off the tool before installing or removing of the battery cartridge.

CAUTION: Hold the tool and the battery cartridge firmly when installing or removing battery cartridge. Failure to hold the tool and the battery cartridge firmly may cause them to slip off your hands and result in damage to the tool and battery cartridge and a personal injury.

To install the battery cartridge, align the tongue on the battery cartridge with the groove in the housing and slip it into place. Insert it all the way until it locks in place with a little click. If you can see the red indicator as shown in the figure, it is not locked completely.

To remove the battery cartridge, slide it from the tool while sliding the button on the front of the cartridge.

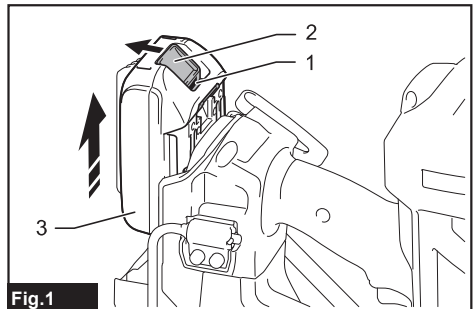

Fig.1

► 1. Red indicator 2. Button 3. Battery cartridge

CAUTION: Always install the battery cartridge fully until the red indicator cannot be seen. If not, it may accidentally fall out of the tool, causing injury to you or someone around you.

CAUTION: Do not install the battery cartridge forcibly. If the cartridge does not slide in easily, it is not being inserted correctly.

Tool / battery protection system

The tool is equipped with a tool/battery protection system. This system automatically cuts off power to the motor to extend tool and battery life. The tool will automatically stop during operation if the tool or battery is placed under one of the following conditions:

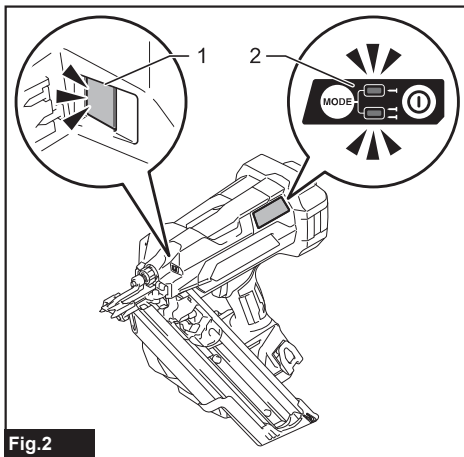

Fig. 2

► 1. Lamp 2. Power/mode indicator

* The switch design varies depending on your region of residence.

Protection status indication

Lamp		Power/mode indicator		Status
On	Blinking	On	Blinking	
■	▣	■	▣	Overheat
■	▣	▣	▣	
■	■	■	■	Over discharge

Overheat protection

When the tool/battery is overheated, the tool stops automatically providing status indication. In this situation, let the tool/battery cool before turning the tool on again.

Overdischarge protection

When the battery capacity becomes low, the tool stops automatically. In this case, remove the battery from the tool and charge the battery.

Protections against other causes

Protection system is also designed for other causes that could damage the tool and allows the tool to stop automatically. Take all the following steps to clear the causes, when the tool has been brought to a temporary halt or stop in operation.

1. Turn the tool off, and then turn it on again to restart.
2. Charge the battery(ies) or replace it/them with recharged battery(ies).
3. Let the machine and battery(ies) cool down.

If no improvement can be found by restoring protection

system, then contact your local Makita Service Center.

Indicating the remaining battery capacity

Only for battery cartridges with the indicator

Press the check button on the battery cartridge to indicate the remaining battery capacity. The indicator lamps light up for a few seconds.

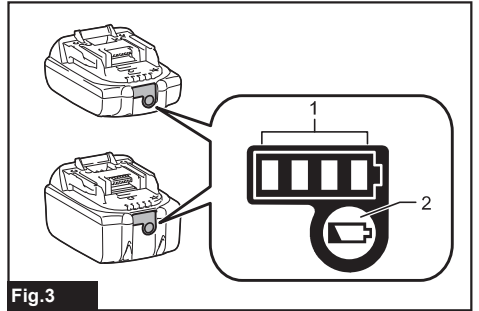

Fig. 3

► 1. Indicator lamps 2. Check button

Indicator lamps			Remaining capacity
Lighted	Off	Blinking	
■ ■ ■ ■			75% to 100%
■ ■ ■	▣		50% to 75%
■ ■	▣ ▣		25% to 50%
■	▣ ▣ ▣		0% to 25%
▣	▣ ▣ ▣		Charge the battery.
■ ■	▣ ▣	▣	The battery may have malfunctioned.
▣ ▣	■ ■		

NOTE: Depending on the conditions of use and the ambient temperature, the indication may differ slightly from the actual capacity.

NOTE: The first (far left) indicator lamp will blink when the battery protection system works.

Power switch action

CAUTION: Before installing the battery cartridge into the tool, always check to see that the switch trigger actuates properly and returns to the "OFF" position when released.

Press and hold the main power button to turn on the tool. The power indicator lights up. To turn off the tool, press and hold the main power button until the power indicator goes off.

NOTE: The switch design varies depending on your region of residence.

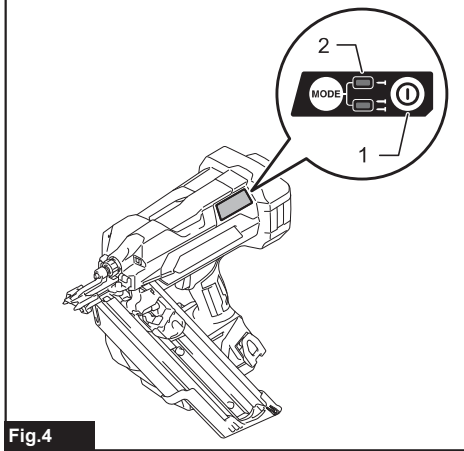

Fig.4

► 1. Main power button 2. Power indicator

NOTE: The tool cannot be turned on while either the switch trigger or the contact element is actuated. Be sure to release the switch trigger and the contact element before turning on the tool.

NOTE: The tool cannot be turned off while driving nails.

NOTE: The main power switch will automatically shut down if the tool is left unattended for an extended duration.

Selecting actuation mode

Country specific

NOTE: Only a single nailing mode is available in some regions or countries. The switch design varies depending on your region of residence.

The tool employs a selective-actuation triggering. Press and shortly hold the actuation mode switch button to select the desired actuation mode.

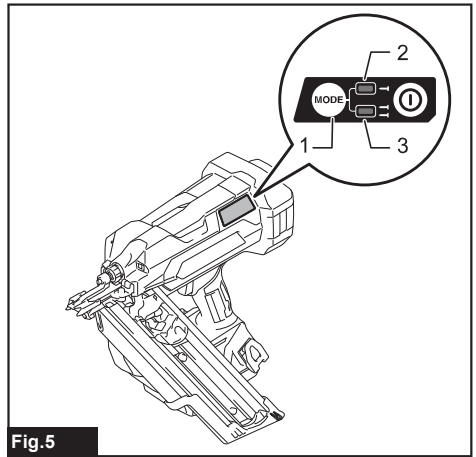

Fig.5

► 1. Actuation mode switch button 2. Sequential actuation mode lamp 3. Contact actuation mode lamp

Mode switch	Actuation mode	Feature
	Full sequential actuation	Drive one nail in one sequential operation. Suitable for driving a nail carefully and accurately and helpful when you require precise fastener placement.
	Contact actuation	Either a single nailing or continuous nailing is available. Preferred when you require high productive fastener placement.

: Unavailable in some regions and countries.

NOTE: Actuation mode cannot be switched to another while either the switch trigger or the contact element is actuated.

Adjusting the nailing depth

⚠WARNING: Always make sure that your fingers are not placed on the switch trigger or the contact element and the battery cartridge is removed before adjusting the depth of nailing.

Turn the adjuster to adjust the nailing depth. The nailing depth gets deeper as you turn the adjuster to A direction, shallower to B direction in the figure. The range of the nailing depth adjustment is 8.5 mm.

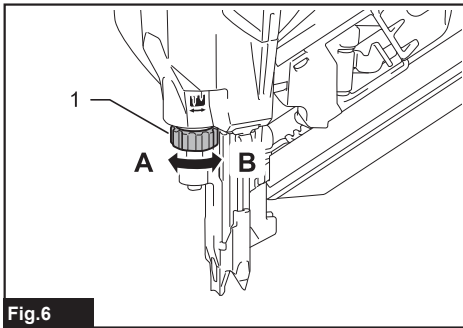

Fig.6

► 1. Adjuster

NOTICE: Do not turn the adjuster too much, or the adjuster may get stuck.

Adjust the nailing depth as necessary.

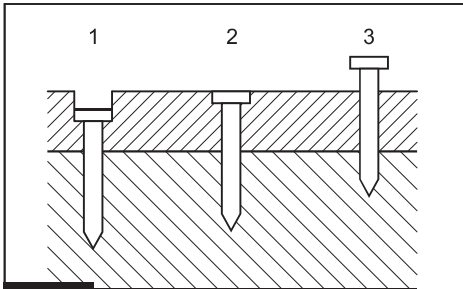

Fig.7

► 1. Too deep 2. Flush 3. Too shallow

Lighting up the lamp

CAUTION: Do not look in the light or see the source of light directly.

Pull the switch trigger or actuate the contact element to light up the lamp. The lamp keeps on lighting while pulling the switch trigger or actuating the contact element. The lamp goes out approximately 10 seconds after releasing the switch trigger and the contact element.

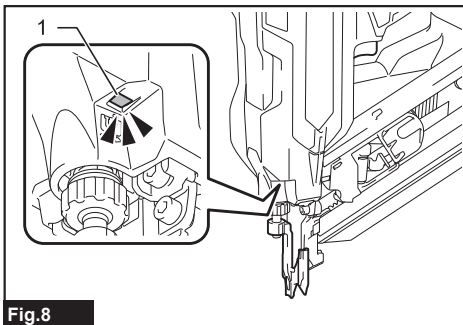

Fig.8

► 1. Lamp

NOTE: Use a dry cloth to wipe the dirt off the lens of the lamp. Be careful not to scratch the lens of the lamp, or it may lower the illumination.

NOTE: The tool may not drive nails after the battery becomes low on power even while the lamp remains lit. In this case, charge the battery cartridge.

ASSEMBLY

CAUTION: Always make sure that your fingers are not placed on the switch trigger or the contact element and the battery cartridge is removed before carrying out any work on the nailer.

Loading or unloading the nails

CAUTION: Always make sure that the battery cartridge is removed before loading the nails. Unintentional firing may cause personal injuries and property damage.

CAUTION: Be careful not to get your fingers caught in the magazine. The nail pusher tends to spring back to its original position unless you take the counteraction.

NOTICE: Gently slide the nail pusher along the magazine. A forceful contact between the nail pusher and nail strip may damage the nails.

1. Remove the battery cartridge.
2. Insert a nail strip into the slit of the magazine.

Make sure to align the outlines of the nail heads with that of the slit.

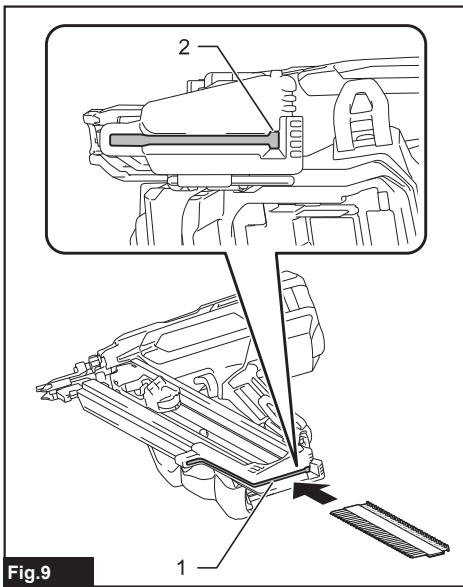

Fig.9

► 1. Slit 2. Nail head outline

3. Pinch the pusher lever to raise the pusher plate up above the nail strip loaded. Then pull the nail pusher towards the slit.

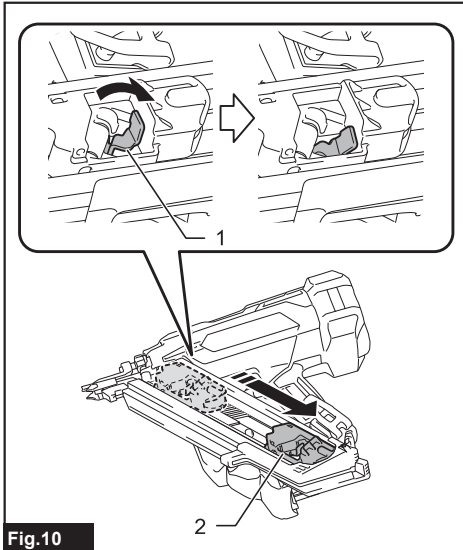

Fig.10

► 1. Pusher lever 2. Nail pusher

4. Set the pusher lever free and slide the nail pusher back by releasing the spring tension safely.

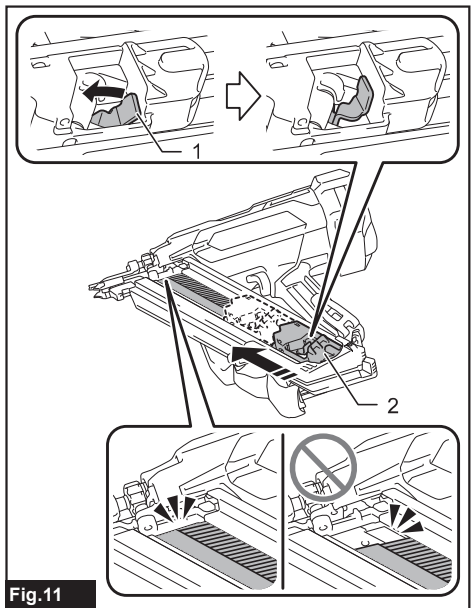

Fig.11

► 1. Pusher lever 2. Nail pusher

NOTICE: Make sure that the nail strip is properly aligned in the magazine and secured with the pusher plate.

If not, try reloading.

NOTICE: Do not use deformed nails and nail strips. Use nails specified in this manual. Using nails other than those specified may cause nail jamming and malfunction.

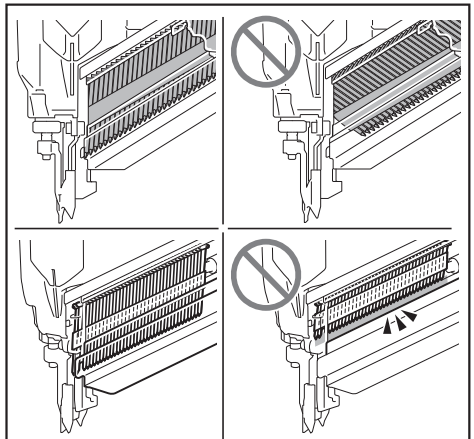

Fig.12

To remove nails, follow the installation procedures in reverse.

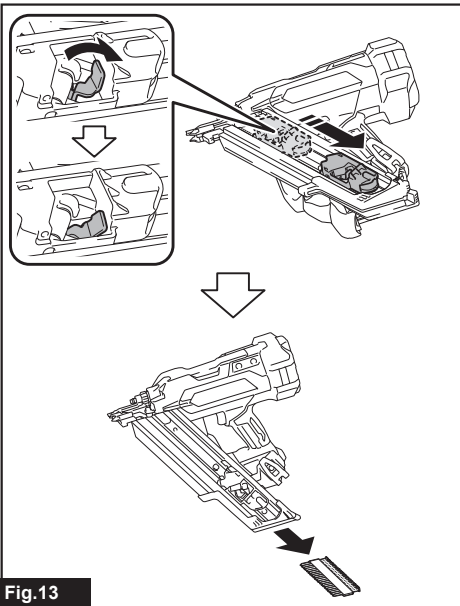

Fig.13

Installing extended capacity magazine

Optional accessory

CAUTION: Always make sure to unload all the nails left in the magazine and remove the battery cartridge from the tool before installing an extended capacity magazine.

Use a large-capacity magazine attachment so the tool carries more nails.

1. Loosen and remove the bolts that secure the magazine using the hex wrench.

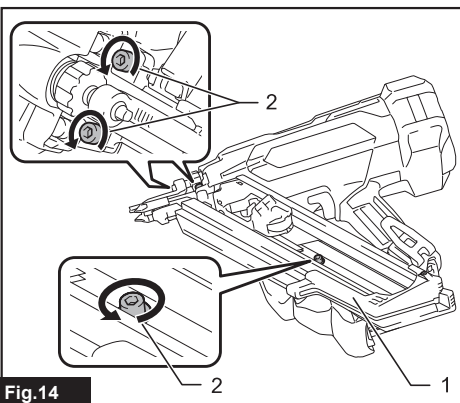

Fig.14

1. Magazine 2. Bolts

2. Lift the free end of the standard equipped magazine slightly and pull it straight out.

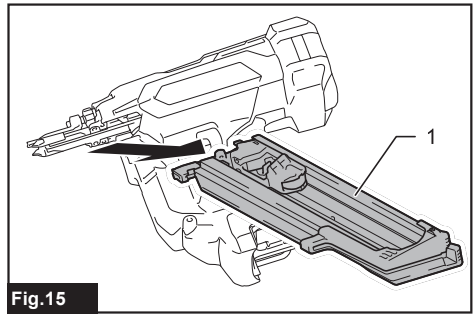

Fig.15

1. Standard equipped magazine

3. Insert the lock plate in the extended capacity magazine into the lock groove in the driver guide at an angle. Align the bolt holes in the magazine with those in the driver guide. Then tighten the bolts a little at a time using the hex wrench.

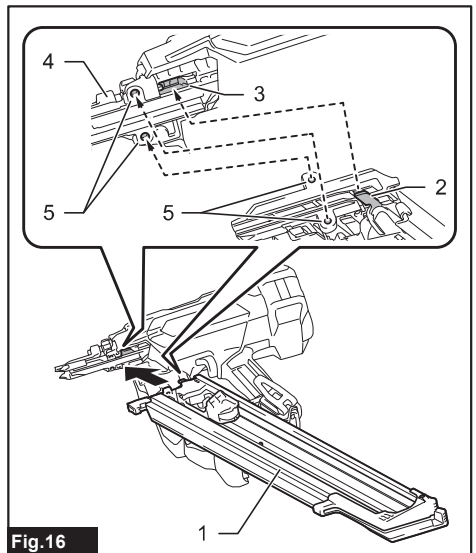

Fig.16

1. Extended capacity magazine 2. Lock plate 3. Lock groove 4. Driver guide 5. Bolt holes

4. Tighten the extended capacity magazine on the tool body with the bolt.
5. Retighten all the bolts up to secure the extended capacity magazine.

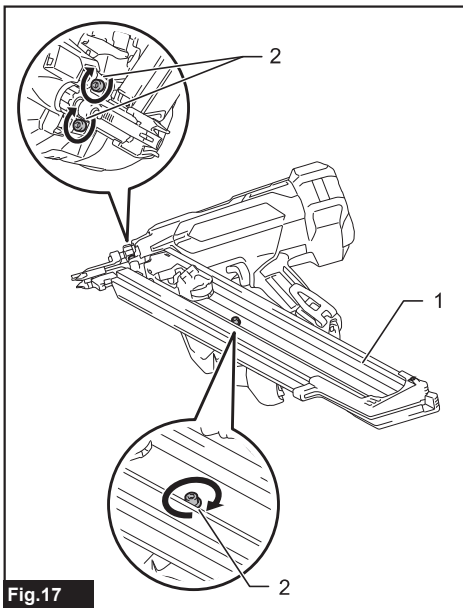

Fig.17

► 1. Extended capacity magazine 2. Bolts

Nose adapter

⚠CAUTION: Always make sure that your fingers are not placed on the switch trigger or the contact element, and remove all the nails left in the magazine and the battery cartridge before attaching or detaching the nose adapter.

When firing nails on the material with easily-marred surfaces, attach the nose adapter onto the contact top.

Attaching nose adapter

1. Lightly place the nose adapter over the contact top.
2. Release the switch trigger.
3. Place the contact element flat on the material that can be damaged.
4. Push the contact element through until the nose adapter securely fits onto the contact top.

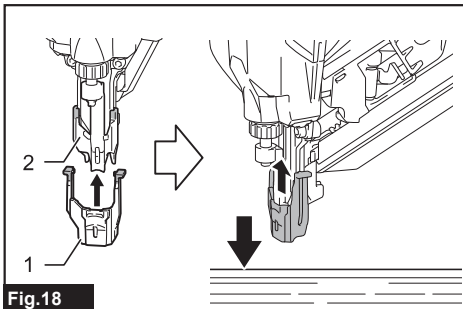

Fig.18

► 1. Nose adapter 2. Contact top

NOTE: Make sure that the hooked arm ends of the nose adapter fully engage the contact top.

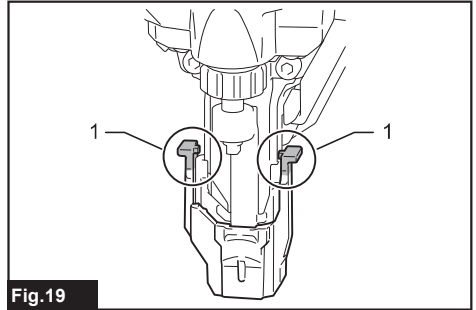

Fig.19

► 1. Hooked arm ends

Detaching nose adapter

1. Turn the tool upside down.
2. Disengage the arms of the nose adapter from the contact top and slide the nose adapter out a bit to make a gap between their outlines.
3. Insert a flat head tool into the gap and pry apart pieces.

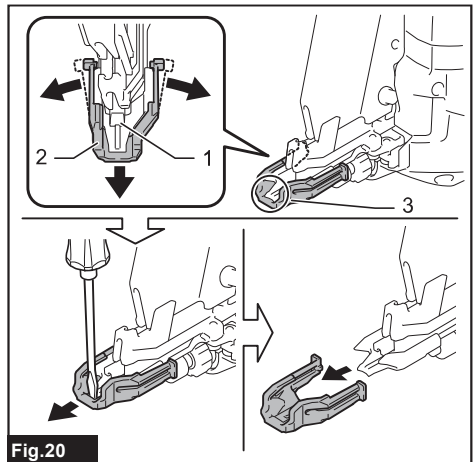

Fig.20

► 1. Contact top 2. Nose adapter 3. Gap

Tool hanging

Two types of tool hooks are available according to your needs. Use either a clip-shaped hook or C-shaped hook to hang the tool on a tool rack, rail or the wall.

⚠CAUTION: Do not hang the hook from the waist belt. Dropping the nailer, which is caused by the hook accidentally coming out of place, may cause unintentional firing and result in personal injuries.

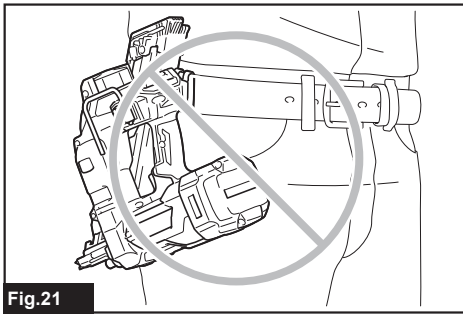

Fig.21

Clip-shaped hook

Insert the clip-shaped hook into a groove in the tool housing, and then secure it with a hex bolt. To remove the clip-shaped hook, loosen the bolt and then take the hook out.

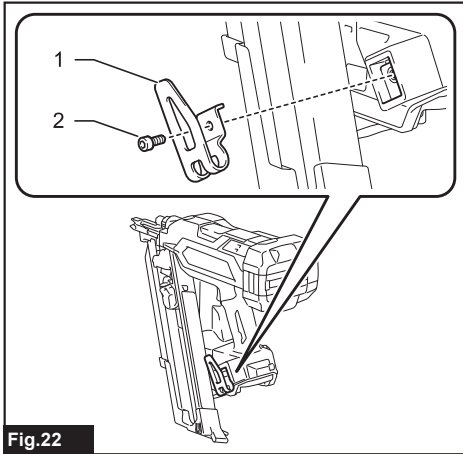

Fig.22

► 1. Clip-shaped hook 2. Hex bolt

Clip-shaped hook

Aligning the two sets of bolt holes, place the C-shaped hook on the tool housing with the opening of the C-shaped hook faces upwards. Tighten the C-shaped hook with two hex bolts.

To remove the C-shaped hook, loosen the bolts and then take the hook out.

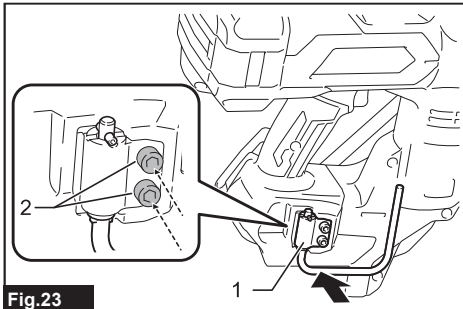

Fig.23

► 1. C-shaped hook 2. Hex bolts

The C-shaped hook can be positioned open at 90-degree intervals. Push and hold the hook upwards and swing it to your desired position.

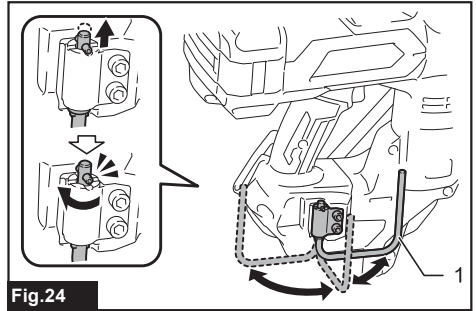

Fig.24

► 1. C-shaped hook

Hex wrench storage

Keep the hex wrench supplied ready on the wrench holder while it is not in use.

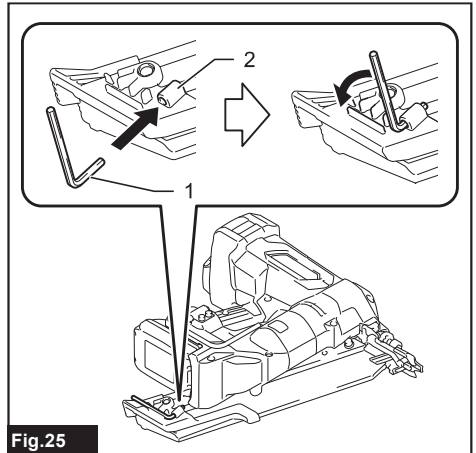

Fig.25

► 1. Hex wrench 2. Wrench holder

OPERATION

Testing safety system

⚠ WARNING: Make sure all safety systems are in working order before operation. Failure to do so may cause personal injuries.

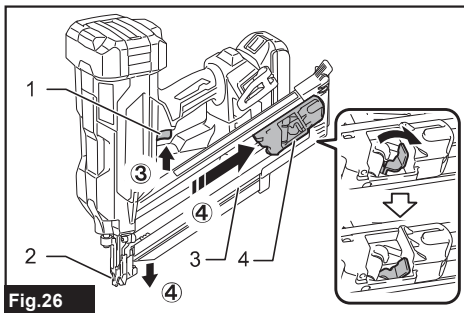

Fig.26

- ▶ 1. Switch trigger 2. Contact element 3. Magazine
- 4. Nail pusher

Test safety system as follows for possible fault or malfunction before operation.

1. Remove the battery cartridge from the tool. Then unload all the nails left in the magazine.
2. Install the battery cartridge in place and turn the tool on.
3. Pull the switch trigger without placing the contact element against the material.
4. Pull the nail pusher towards the magazine slit and hold it in place. Then place the contact element against the material without pulling the switch trigger.

If the tool works in case step 3 or 4 described above, safety system is not functioning properly. Stop using the tool immediately and ask your local Makita Service Center.

Driving nails

⚠ WARNING: Continue to place the contact element firmly on the material until the nail is driven completely. Unintentional firing may cause personal injuries.

⚠ CAUTION: Before installing the battery cartridge into the tool, always check to see that the switch trigger actuates properly and returns to the "OFF" position when released.

⚠ CAUTION: Do not drive nails on hard materials such as metal or the like. If the nail cannot penetrate the material, the nailer may be kicked back toward you and cause injury.

⚠ CAUTION: Hold the tool firmly during operation.

NOTICE: The tool will not start fastening after five seconds no switch operation while either the switch trigger or the contact element is being solely actuated. Release the switch trigger or pull the contact element free from the workpiece, and then reposition the tool in place to restart fastening.

NOTE: If you drive nails continuously for a long time, the exhaust air will get hot due to the heat from the motor.

The tool employs two nailing actions; full sequential

actuation and contact actuation.

NOTE: Only a single nailing mode (full sequential actuation) is available in some regions or countries. The switch design varies depending on your region of residence.

Full sequential actuation

In this mode, you can drive one nail by one sequential operation.

A workpiece contact and then a trigger need to be activated in a specific sequence to actuate the tool. Release and re-activate the switch controls in the same sequence to continue driving nails.

1. Press and hold the main power button to turn on the tool.
2. Make sure that the sequential actuation mode lamp lights up.

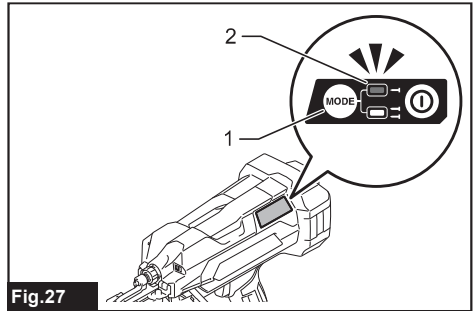

Fig.27

- ▶ 1. Actuation mode switch button 2. Sequential actuation mode lamp

3. Place the contact element flat on the material.

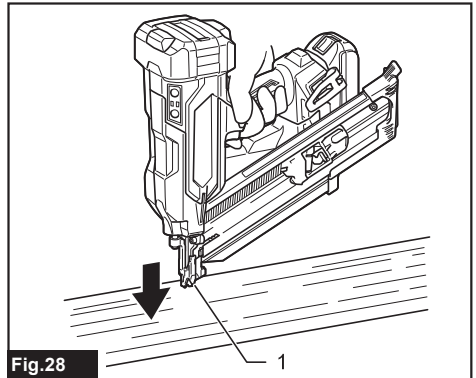

Fig.28

- ▶ 1. Contact element
4. Pull the switch trigger fully to drive a nail.

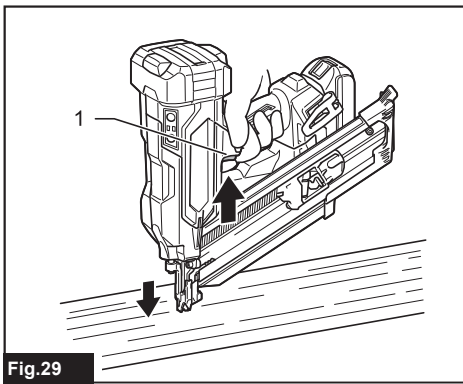

Fig.29

► 1. Switch trigger

5. Release your finger from the switch trigger. Then lift the contact element up from the material.

To drive the next nail, repeat the steps 3 and 4 in the same sequence.

Contact actuation

Country specific

In this mode, you can choose either continuous or single nailing by following any sequences of the trigger operation.

A workpiece contact and a trigger can be activated in any sequences to actuate the tool. Release and re-activate the workpiece contact to continuously drive nails.

For a single nailing

1. Press and hold the main power button to turn on the tool.
2. Press and shortly hold the actuation mode switch button to select the contact actuation mode.

The contact actuation mode lamp lights up.

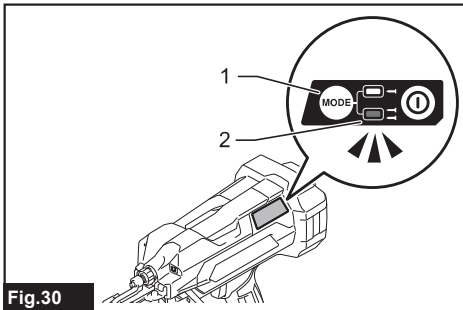

Fig.30

► 1. Actuation mode switch button 2. Contact actuation mode lamp

3. Place the contact element flat on the material.

4. Pull the switch trigger fully to drive a nail.

5. Release your finger from the switch trigger. Then lift the contact element up from the material.

To drive the next nail, repeat the steps 3 and 4 in the same sequence.

For a continuous nailing

1. Press and hold the main power button to turn on the tool.

2. Press and shortly hold the actuation mode switch button to select the contact actuation mode.

The contact actuation mode lamp lights up.

3. Pull the switch trigger.

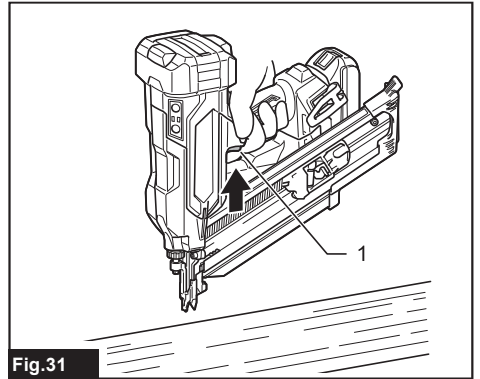

Fig.31

► 1. Switch trigger

4. Place the contact element flat on the material to drive a nail.

5. Move the tool to the next areas with the switch trigger pulled, and place the contact element flat on the material to drive following nails.

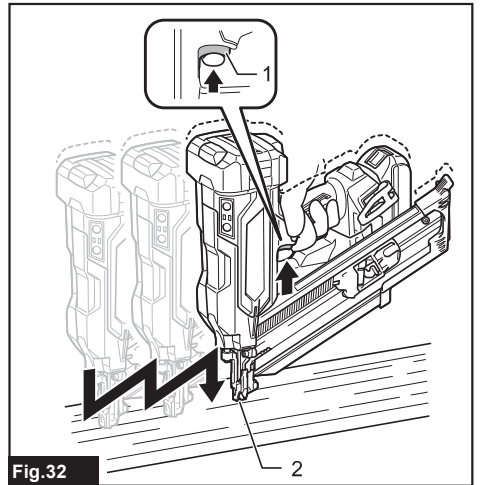

Fig.32

► 1. Switch trigger 2. Contact element

Anti dry fire mechanism

When the remaining nails in the magazine decrease to *** - *** pieces, the switch trigger can no longer be pulled. At this time, insert a new strip of nails in the magazine and the switch trigger can be pulled again.

Removing jammed nails

⚠ WARNING: Always make sure that the battery cartridge is removed before removing jammed nails.

When a nail jamming occurs, look over closely the nail feeding and driving unit. Jams tend to be caused by nails wedged between the nail driver and the driver guide.

Clearing a jam

⚠ WARNING: Do not push on the nail driver forcibly. Do not strike the nail driver and nails with any hand tools to clear jams. Mind that the tool is charged with compressed air and the pressure is maintained inside. Failure to follow the safety precautions in the manual can result in serious injury.

⚠ WARNING: Never point the tool at yourself or other persons nearby when clearing jams. Failure to do so may cause a risk of injury by misfiring since the tool is charged with compressed air in a factory sealed chamber.

⚠ CAUTION: To address frequent jamming or hard-to-clear jamming situations, consult your local Makita Service Center.

1. Remove the battery cartridge from the tool.
2. Take out all the nails left in the magazine.
3. Clear a jam using pliers or the like.

NOTE: Dismount the magazine from the tool if jamming occurs inside the nail feeding and driving unit.

4. Loosen and remove the bolts that secure the magazine using the hex wrench. Then lift the free end of the magazine slightly and pull it straight out.

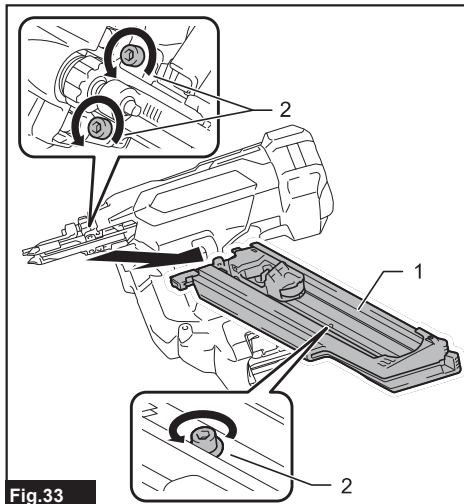

Fig.33

- 1. Magazine 2. Bolts

5. Clear jammed nails in the nail exit opening or

through the driver guide.

Use pliers to bend the jammed nail so that the nail head comes out of the slot in the driver guide. Then remove the jammed nail.

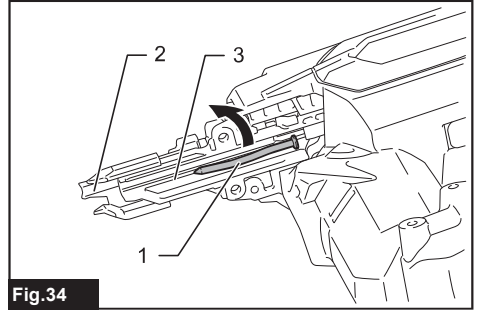

Fig.34

- 1. Jammed nail 2. Nail exit opening 3. Driver guide

A jamming may occur at the nail feeding slot in the magazine. Use pliers to bend the jammed nail so that the nail head comes out of the slot in the magazine. Then remove the jammed nail.

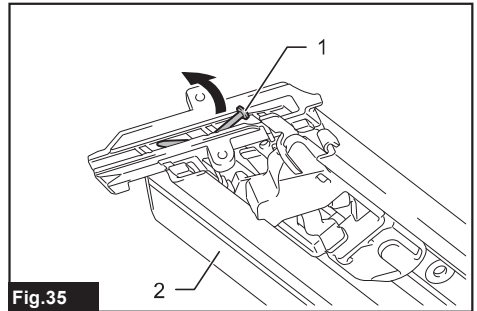

Fig.35

- 1. Jammed nail 2. Magazine

6. Insert the lock plate in the magazine into the lock groove in the driver guide at an angle. Align the bolt holes in the magazine with those in the driver guide. Tighten the magazine on the tool body with the bolts.

Initializing driver position

The nail driver may not be positioned correctly behind the nail to be driven next after a nail jamming or under low battery condition. Always perform initialization steps before you restart operation.

1. Remove the battery cartridge from the tool.
2. Take out all the nails left in the magazine.
3. Observe the nail driver position.

If you see the driver tip out of the contact top, the contact element cannot correctly be actuated during initialization.

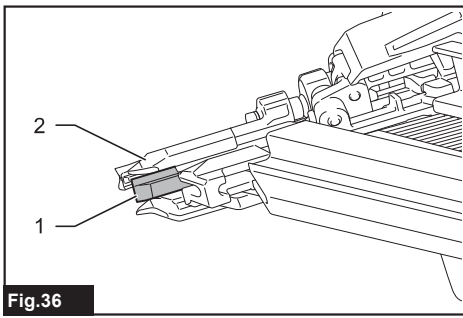

Fig.36

► 1. Nail driver 2. Contact top

Turn the adjuster to set the shallowest nailing depth so that the contact element functions properly.

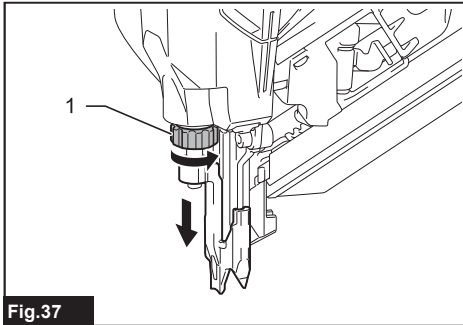

Fig.37

► 1. Nailing depth adjuster

4. Install the battery cartridge in place and turn the tool on.
5. Pull the nail pusher towards the magazine slit and hold it in place. Then place the contact element against the material that can be damaged.
6. Pull the switch trigger fully, with the contact element actuated, to reset the driver position .

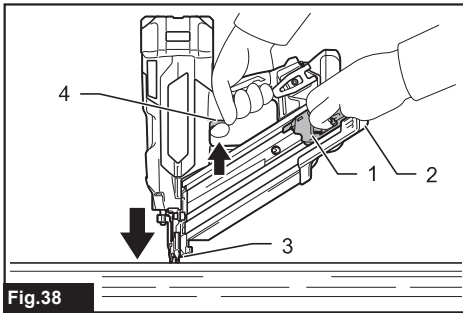

Fig.38

► 1. Nail pusher 2. Magazine slit 3. Contact element 4. Switch trigger

The driver position will be initialized correctly.

7. Remove the battery cartridge from the tool. Reload the nail strip in the magazine. Place the battery cartridge back into the tool.

MAINTENANCE

CAUTION: Always be sure that the tool is switched off and the battery cartridge is removed before attempting to perform inspection or maintenance.

NOTICE: Never use gasoline, benzine, thinner, alcohol or the like. Discoloration, deformation or cracks may result.

To maintain product SAFETY and RELIABILITY, repairs, any other maintenance or adjustment should be performed by Makita Authorized or Factory Service Centers, always using Makita replacement parts.

Preventive maintenance

Thoroughly clean and inspect moving components (i.e., contact element, nail pusher, etc.) on a regular basis, keeping them free of dust and dirt that may accumulate over time.

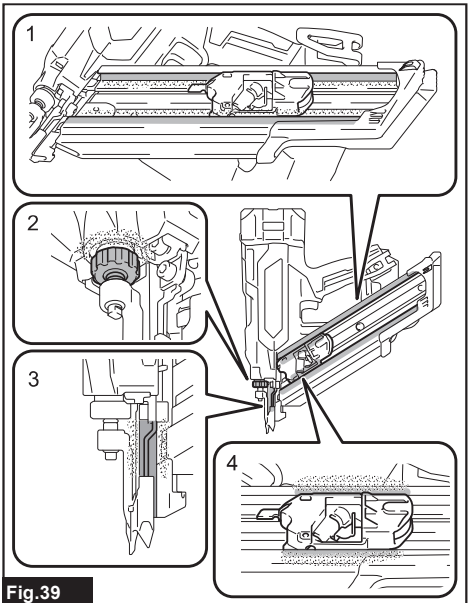

Fig.39

► 1. Nail feeding rails 2. Nailing depth adjuster 3. Contact element 4. Nail pusher

OPTIONAL ACCESSORIES

⚠ CAUTION: These accessories or attachments are recommended for use with your Makita tool specified in this manual. The use of any other accessories or attachments might present a risk of injury to persons. Only use accessory or attachment for its stated purpose.

If you need any assistance for more details regarding these accessories, ask your local Makita Service Center.

- Nails
- Extended capacity magazines
- Makita genuine battery and charger

NOTE: Some items in the list may be included in the tool package as standard accessories. They may differ from country to country.

Makita Europe N.V.

Jan-Baptist Vinkstraat 2, 3070 Kortenberg, Belgium

Makita Corporation

3-11-8, Sumiyoshi-cho, Anjo, Aichi 446-8502 Japan

www.makita.com



885A75-220 EN 20240228
