

Technical Information

D4066

1 Outline

Title	Change of Cylinder end and O ring 14
Model	DBN500, XNB01 Note: These models are the subject items under Export Trade Control Order of Japan. Provision of the items or technical information is strictly prohibited without specific approval of Japanese government. Do not provide this information to anyone who is not permitted to handle the technical information.
Country	All countries
Description	Cylinder end and O ring 14 will be changed to improve productivity.

2 Detailed information

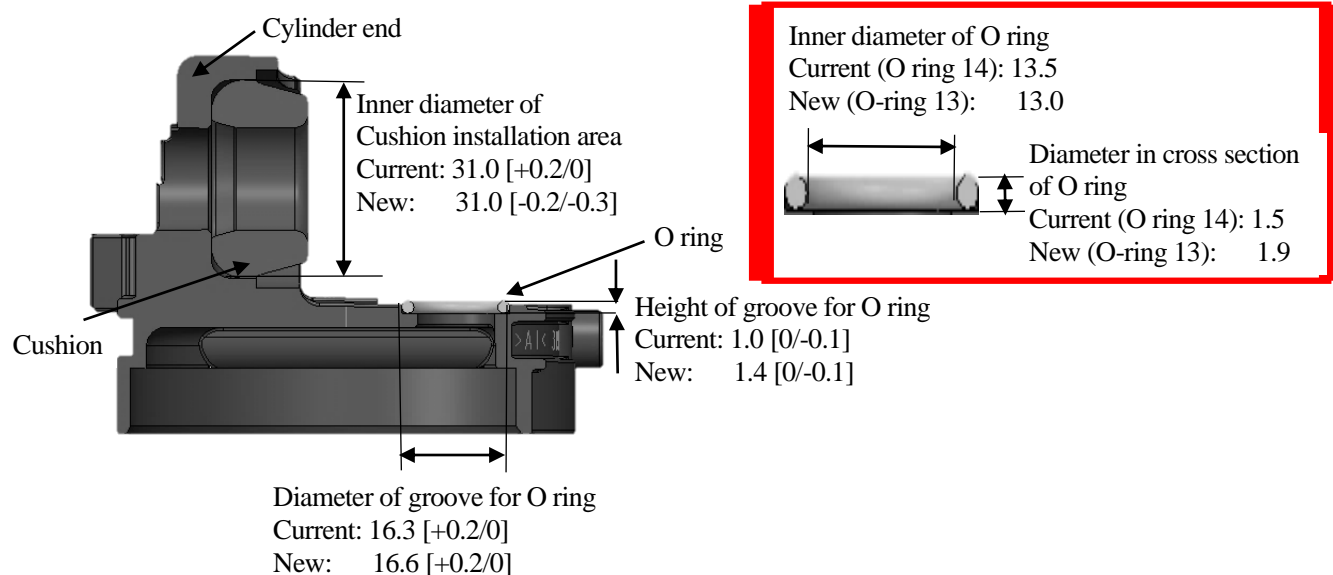

3 Parts information

	Item No.	Current part	Q'ty	I/C	H/S	S/P	New part	Q'ty	Note
[1]	081	CYLINDER END 319115-5	1	S	OK	D	CYLINDER END 312A55-2	1	Interchangeable as a set
[2]	084	O RING 14 213162-7	1	S	OK	O-RING 13 213238-0	1		

3-1 Marks of Interchangeability (I/C), Handling (H/S), Supplying (S/P)

I/C (Interchangeability)	Yes	The new part can be substituted for the current and the current part can be substituted for the new.
	No	The new part cannot be substituted for the current and the current part cannot be substituted for the new.
	←	The new part can be substituted for the current.
	→	The current part can be substituted for the new.
	S	Interchangeable as a set.
H/S (Handling for plants, agents, and distributors stock of the current parts)	OK	The current parts can be used for the subject item No(s). of the subject model(s).
	NOK	The current parts cannot be used for the subject item No(s). of the subject model(s), but can be used for the other item No(s) or the other models.
	T	The current parts in stock must be thrown away due to the technical reason.
S/P (Supplying the current parts for repair from plants)	L	The plants stop supplying the current parts under the above conditions [Model(s), Countries, Item No(s)]. However, they can supply the current parts under other conditions.
	D	The plants stop supplying the current parts.
	C	The plants continue to supply the current parts.
	Z	The plants continue supplying only for a certain period or amount.
	A	After the current parts in plant stock are cleared, they will be discontinued.

4 Implementation

After the current parts in stock are cleared.