

INSTRUCTION MANUAL

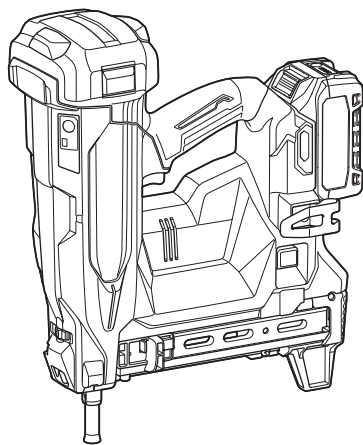

# Cordless Concrete Nailer

## BN003G



Read before use.

# SPECIFICATIONS

<b>Model:</b>	<b>BN003G</b>
Nail length	15 mm - 40 mm
Shank diameter	ø2.6 mm - ø3.1 mm
Magazine capacity	25 pcs.
Dimensions (L x W x H) <sup>1 2</sup>	314 mm x 149 mm x 391 mm
Rated voltage	D.C. 36 V - 40 V max
Net weight	*** - *** kg

<sup>1</sup> without hook

<sup>2</sup> with BL4025

**NOTE:** Nails are referred to as "fasteners" in this instruction manual unless otherwise specified.

- Due to our continuing program of research and development, the specifications herein are subject to change without notice.
- Specifications may differ from country to country.
- The net weight value includes the lightest and heaviest combination of the attachment(s) for normal and safe use and battery cartridge(s) which are specified in the instruction manual.

## Applicable battery cartridge and charger

Battery cartridge	BL4020* / BL4025* / BL4040* / BL4040F* / BL4050F / BL4080F / BL4080H * : Recommended battery
Charger	DC40RA / DC40RB / DC40RC / DC40WA / BCC01 / BCC02

- Some of the battery cartridges and chargers listed above may not be available depending on your region of residence.

**⚠ WARNING:** Only use the battery cartridges and chargers listed above. Use of any other battery cartridges and chargers may cause injury and/or fire.

## Symbols

The followings show the symbols which may be used for the equipment. Be sure that you understand their meaning before use.

	Take particular care and attention.
	Read instruction manual.
 	Wear eye protection.
 	Wear ear protection.
	Remove the battery cartridge and fasteners before maintenance, unjamming, or when not in use.
	NEVER point the tool at yourself or others in work area.
	Do not use on scaffoldings, ladders.
	Understand the trigger system of the tool. Check the instruction manual.



Only for EU countries  
Due to the presence of hazardous components in the equipment, waste electrical and electronic equipment, accumulators and batteries may have a negative impact on the environment and human health. Do not dispose of electrical and electronic appliances or batteries with household waste!  
In accordance with the European Directive on waste electrical and electronic equipment and on accumulators and batteries and waste accumulators and batteries, as well as their adaptation to national law, waste electrical equipment, batteries and accumulators should be stored separately and delivered to a separate collection point for municipal waste, operating in accordance with the regulations on environmental protection.  
This is indicated by the symbol of the crossed-out wheeled bin placed on the equipment.

## Intended use

The tool is intended for securing a thin steel plate to the concrete.

## Noise

The typical A-weighted noise level determined according to EN62841-2-16:

Sound pressure level ( $L_{pA}$ ) : \*\*\* dB (A)

Sound power level ( $L_{WA}$ ) : \*\*\* dB (A)

Uncertainty (K) : \*\*\* dB (A)

**NOTE:** The declared noise emission value(s) has been measured in accordance with a standard test method and may be used for comparing one tool with another.

**NOTE:** The declared noise emission value(s) can also be used in a preliminary assessment of exposure.

**⚠ WARNING:** Wear ear protection.

**⚠ WARNING:** The noise emission during actual use of the power tool can differ from the declared total value(s) depending on the ways in which the tool is used.

**⚠ WARNING:** Be sure to identify safety measures to protect the operator that are based on an estimation of exposure in the actual conditions of use (taking account of all parts of the operating cycle such as the times when the tool is switched off and when it is running idle in addition to the trigger time).

## Vibration

The continuous vibration total value (tri-axial vector sum) determined according to EN62841-2-16:  
Vibration emission ( $a_w$ ) : \*\*\*  $m/s^2$   
Uncertainty (K) : 1.5  $m/s^2$

**NOTE:** The declared vibration total value(s) has been measured in accordance with a standard test method and may be used for comparing one tool with another.

**NOTE:** The declared vibration total value(s) can also be used in a preliminary assessment of exposure.

**⚠ WARNING:** The vibration emission during actual use of the power tool can differ from the declared total value(s) depending on the ways in which the tool is used.

**⚠ WARNING:** Be sure to identify safety measures to protect the operator that are based on an estimation of exposure in the actual conditions of use (taking account of all parts of the operating cycle such as the times when the tool is switched off and when it is running idle in addition to the trigger time).

The following shows the mean values of the peak amplitude of the acceleration from repeated shock vibrations,  $p_F$ , with corresponding uncertainty (K) determined according to EN62841-2-16.

$p_F$  : \*\*\*  $m/s^2$   
Uncertainty (K) : \*\*\*  $m/s^2$

**NOTE:** These declared values should not be used to determine hand arm vibration exposure.

## Declarations of Conformity

### For European countries only

The EU/UK Declaration of Conformity can be accessed from the following URL.



[https://support.makita.biz/doc/doc\\_index.html](https://support.makita.biz/doc/doc_index.html)

## SAFETY WARNINGS

### General power tool safety warnings

**⚠ WARNING** Read all safety warnings, instructions, illustrations and specifications provided with this power tool. Failure to follow all instructions listed below may result in electric shock, fire and/or serious injury.

### Save all warnings and instructions for future reference.

The term "power tool" in the warnings refers to your mains-operated (corded) power tool or battery-operated (cordless) power tool.

#### Work area safety

1. **Keep work area clean and well lit.** Cluttered or dark areas invite accidents.
2. **Do not operate power tools in explosive atmospheres, such as in the presence of flammable liquids, gases or dust.** Power tools create sparks which may ignite the dust or fumes.
3. **Keep children and bystanders away while operating a power tool.** Distractions can cause you to lose control.

#### Electrical safety

1. **Power tool plugs must match the outlet. Never modify the plug in any way. Do not use any adapter plugs with earthed (grounded) power tools.** Unmodified plugs and matching outlets will reduce risk of electric shock.
2. **Avoid body contact with earthed or grounded surfaces, such as pipes, radiators, ranges and refrigerators.** There is an increased risk of electric shock if your body is earthed or grounded.
3. **Do not expose power tools to rain or wet conditions.** Water entering a power tool will increase the risk of electric shock.
4. **Do not abuse the cord. Never use the cord for carrying, pulling or unplugging the power tool. Keep cord away from heat, oil, sharp edges or moving parts.** Damaged or entangled cords increase the risk of electric shock.
5. **When operating a power tool outdoors, use an extension cord suitable for outdoor use.** Use of a cord suitable for outdoor use reduces the risk of electric shock.
6. **If operating a power tool in a damp location is unavoidable, use a residual current device (RCD) protected supply.** Use of an RCD reduces the risk of electric shock.
7. **Power tools can produce electromagnetic fields (EMF) that are not harmful to the user.**

However, users of pacemakers and other similar medical devices should contact the maker of their device and/or doctor for advice before operating this power tool.

### Personal safety

1. **Stay alert, watch what you are doing and use common sense when operating a power tool. Do not use a power tool while you are tired or under the influence of drugs, alcohol or medication.** A moment of inattention while operating power tools may result in serious personal injury.
2. **Use personal protective equipment. Always wear eye protection.** Protective equipment such as a dust mask, non-skid safety shoes, hard hat or hearing protection used for appropriate conditions will reduce personal injuries.
3. **Prevent unintentional starting. Ensure the switch is in the off-position before connecting to power source and/or battery pack, picking up or carrying the tool.** Carrying power tools with your finger on the switch or energising power tools that have the switch on invites accidents.
4. **Remove any adjusting key or wrench before turning the power tool on.** A wrench or a key left attached to a rotating part of the power tool may result in personal injury.
5. **Do not overreach. Keep proper footing and balance at all times.** This enables better control of the power tool in unexpected situations.
6. **Dress properly. Do not wear loose clothing or jewellery. Keep your hair and clothing away from moving parts.** Loose clothes, jewellery or long hair can be caught in moving parts.
7. **If devices are provided for the connection of dust extraction and collection facilities, ensure these are connected and properly used.** Use of dust collection can reduce dust-related hazards.
8. **Do not let familiarity gained from frequent use of tools allow you to become complacent and ignore tool safety principles.** A careless action can cause severe injury within a fraction of a second.
9. **Always wear protective goggles to protect your eyes from injury when using power tools. The goggles must comply with ANSI Z87.1 in the USA, EN 166 in Europe, or AS/NZS 1336 in Australia/New Zealand. In Australia/New Zealand, it is legally required to wear a face shield to protect your face, too.**

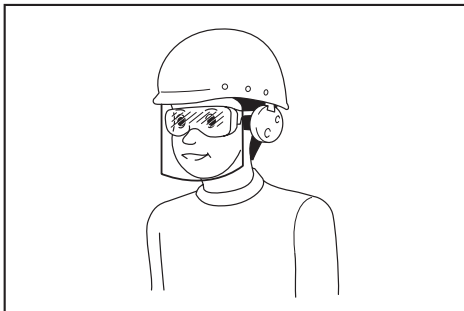

It is an employer's responsibility to enforce

**the use of appropriate safety protective equipments by the tool operators and by other persons in the immediate working area.**

### Power tool use and care

1. **Do not force the power tool. Use the correct power tool for your application.** The correct power tool will do the job better and safer at the rate for which it was designed.
2. **Do not use the power tool if the switch does not turn it on and off.** Any power tool that cannot be controlled with the switch is dangerous and must be repaired.
3. **Disconnect the plug from the power source and/or remove the battery pack, if detachable, from the power tool before making any adjustments, changing accessories, or storing power tools.** Such preventive safety measures reduce the risk of starting the power tool accidentally.
4. **Store idle power tools out of the reach of children and do not allow persons unfamiliar with the power tool or these instructions to operate the power tool.** Power tools are dangerous in the hands of untrained users.
5. **Maintain power tools and accessories. Check for misalignment or binding of moving parts, breakage of parts and any other condition that may affect the power tool's operation. If damaged, have the power tool repaired before use.** Many accidents are caused by poorly maintained power tools.
6. **Keep cutting tools sharp and clean.** Properly maintained cutting tools with sharp cutting edges are less likely to bind and are easier to control.
7. **Use the power tool, accessories and tool bits etc. in accordance with these instructions, taking into account the working conditions and the work to be performed.** Use of the power tool for operations different from those intended could result in a hazardous situation.
8. **Keep handles and grasping surfaces dry, clean and free from oil and grease.** Slippery handles and grasping surfaces do not allow for safe handling and control of the tool in unexpected situations.
9. **When using the tool, do not wear cloth work gloves which may be entangled.** The entanglement of cloth work gloves in the moving parts may result in personal injury.

### Battery tool use and care

1. **Recharge only with the charger specified by the manufacturer.** A charger that is suitable for one type of battery pack may create a risk of fire when used with another battery pack.
2. **Use power tools only with specifically designated battery packs.** Use of any other battery packs may create a risk of injury and fire.
3. **When battery pack is not in use, keep it away from other metal objects, like paper clips, coins, keys, nails, screws or other small metal objects, that can make a connection from one terminal to another.** Shorting the battery terminals together may cause burns or a fire.
4. **Under abusive conditions, liquid may be ejected from the battery; avoid contact. If**

**contact accidentally occurs, flush with water. If liquid contacts eyes, additionally seek medical help.** Liquid ejected from the battery may cause irritation or burns.

5. **Do not use a battery pack or tool that is damaged or modified.** Damaged or modified batteries may exhibit unpredictable behaviour resulting in fire, explosion or risk of injury.
6. **Do not expose a battery pack or tool to fire or excessive temperature.** Exposure to fire or temperature above 130 °C may cause explosion.
7. **Follow all charging instructions and do not charge the battery pack or tool outside the temperature range specified in the instructions.** Charging improperly or at temperatures outside the specified range may damage the battery and increase the risk of fire.

#### Service

1. **Have your power tool serviced by a qualified repair person using only identical replacement parts.** This will ensure that the safety of the power tool is maintained.
2. **Never service damaged battery packs.** Service of battery packs should only be performed by the manufacturer or authorized service providers.
3. **Follow instruction for lubricating and changing accessories.**

### Fastener driving tool safety warnings

1. **Always assume that the tool contains fasteners.** Careless handling of the tool may result in unexpected firing of fasteners and personal injury.
2. **Disconnect the tool from the power source when loading and unloading fasteners, making adjustments or changing accessories.** The tool may be accidentally activated if it is connected to the power source, which may result in personal injury.
3. **Be careful when handling fasteners, especially when loading and unloading.** The fasteners have sharp points which may result in personal injury.
4. **Do not point the tool towards yourself or anyone nearby.** Unexpected triggering will discharge a fastener, which may result in personal injury.
5. **Keep fingers away from the trigger when not operating the tool and when moving from one operating position to another.** Unexpected triggering will discharge a fastener, which may result in personal injury.
6. **Hold the tool by insulated gripping surfaces, when performing an operation where the fastener may contact hidden wiring.** A fastener contacting a "live" wire may make exposed metal parts of the tool "live" and could give the operator an electric shock.
7. **Hold the tool with a firm grasp during operation.** Uncontrolled recoil of the tool may result in unintended activation, which may result in personal injury.
8. **Keep all body parts such as hands and legs, etc. away from the firing direction of the tool.**

The fastener may penetrate the workpiece as well as any object behind it, which may result in personal injury.

9. **When using the tool, keep all body parts such as hands and legs, etc. away from the area where the fastener is driven into the workpiece.** The fastener could deflect and exit the workpiece, which may result in personal injury.
10. **Do not actuate the tool unless the tool is placed firmly against the workpiece.** If the tool is not in contact with the workpiece, the fastener may be deflected away from the workpiece, which may result in personal injury.
11. **Do not use this tool for fastening electrical cables.** It is not designed for electric cable installation and may damage the insulation of electric cables, thereby causing electric shock or fire hazards.
12. **Disconnect the tool from the power source if a fastener jams in the tool.** While removing a jammed fastener, the tool may be accidentally activated if it is connected to the power source, which may result in personal injury.
13. **Use caution while removing a jammed fastener.** The mechanism may be under compression and the fastener may be forcefully discharged, which may result in personal injury.

#### Additional safety warnings

1. **Always wear safety glasses to protect your eyes from dust or fastener injury.**
2. **Keep hands and feet away from the ejection port area.**
3. **Make sure no one is nearby before operation. Never attempt to drive fasteners from both the inside and outside of wall at the same time.** Fasteners may rip through and/or fly off, presenting a grave danger.
4. **Watch your footing and maintain your balance with the tool. Make sure there is no one below when working in high locations.**
5. **Never use fastener driving tools marked with the symbol "Do not use on scaffoldings, ladders" for specific application for example:**
  - when changing one driving location to another involves the use of scaffoldings, stairs, ladders, or ladder alike constructions, e.g. roof laths;
  - closing boxes or crates;
  - fitting transportation safety systems e.g. on vehicles and wagons.
6. **Check walls, ceilings, floors, roofing and the like carefully to avoid possible electrical shock, gas leakage, explosions, etc. caused by stapling into live wires, conduits or gas pipes.**
7. **Use only fasteners specified in this manual.** The use of any other fasteners may cause malfunction of the tool.
8. **Do not tamper with the tool or attempt to use it for other than driving fasteners.**
9. **Do not operate the tool without fasteners.** It shortens the service life of the tool.
10. **Stop driving operations immediately if you notice something wrong or out of the ordinary with the tool.**

11. Never fasten into any materials which may allow the fastener to puncture and fly through as a projectile.
12. Never actuate the switch trigger and contact element at the same time until you are prepared to fasten workpieces. Allow the workpiece to depress the contact element. Never defeat its purpose by securing the contact element back or by depressing it by hand.
13. Never tamper with the contact element. Check the contact element frequently for proper operations.
14. Always remove fasteners from the tool when not in use.
15. Avoid placing magnets or similar magnetic device too close to the tool. It may affect the magnetic sensor in the tool.

## SAVE THESE INSTRUCTIONS.

**⚠ WARNING:** DO NOT let comfort or familiarity with product (gained from repeated use) replace strict adherence to safety rules for the subject product. MISUSE or failure to follow the safety rules stated in this instruction manual may cause serious personal injury.

### Important safety instructions for battery cartridge

1. Before using battery cartridge, read all instructions and cautionary markings on (1) battery charger, (2) battery, and (3) product using battery.
2. Do not disassemble or tamper with the battery cartridge. It may result in a fire, excessive heat, or explosion.
3. If operating time has become excessively shorter, stop operating immediately. It may result in a risk of overheating, possible burns and even an explosion.
4. If electrolyte gets into your eyes, rinse them out with clear water and seek medical attention right away. It may result in loss of your eyesight.
5. Do not short the battery cartridge:
  - (1) Do not touch the terminals with any conductive material.
  - (2) Avoid storing battery cartridge in a container with other metal objects such as nails, coins, etc.
  - (3) Do not expose battery cartridge to water or rain.

A battery short can cause a large current flow, overheating, possible burns and even a breakdown.
6. Do not store and use the tool and battery cartridge in locations where the temperature may reach or exceed 50 °C (122 °F).
7. Do not incinerate the battery cartridge even if it is severely damaged or is completely worn out. The battery cartridge can explode in a fire.
8. Do not nail, cut, crush, throw, drop the battery cartridge, or hit against a hard object to the battery cartridge. Such conduct may result in a

fire, excessive heat, or explosion.

9. Do not use a damaged battery.
10. The contained lithium-ion batteries are subject to the Dangerous Goods Legislation requirements.
 

For commercial transports e.g. by third parties, forwarding agents, special requirement on packaging and labeling must be observed.

For preparation of the item being shipped, consulting an expert for hazardous material is required. Please also observe possibly more detailed national regulations.

Tape or mask off open contacts and pack up the battery in such a manner that it cannot move around in the packaging.
11. When disposing the battery cartridge, remove it from the tool and dispose of it in a safe place. Follow your local regulations relating to disposal of battery.
12. Use the batteries only with the products specified by Makita. Installing the batteries to non-compliant products may result in a fire, excessive heat, explosion, or leak of electrolyte.
13. If the tool is not used for a long period of time, the battery must be removed from the tool.
14. During and after use, the battery cartridge may take on heat which can cause burns or low temperature burns. Pay attention to the handling of hot battery cartridges.
15. Do not touch the terminal of the tool immediately after use as it may get hot enough to cause burns.
16. Do not allow chips, dust, or soil stuck into the terminals, holes, and grooves of the battery cartridge. It may cause heating, catching fire, burst and malfunction of the tool or battery cartridge, resulting in burns or personal injury.
17. Unless the tool supports the use near high-voltage electrical power lines, do not use the battery cartridge near high-voltage electrical power lines. It may result in a malfunction or breakdown of the tool or battery cartridge.
18. Keep the battery away from children.

## SAVE THESE INSTRUCTIONS.

**⚠ CAUTION:** Only use genuine Makita batteries. Use of non-genuine Makita batteries, or batteries that have been altered, may result in the battery bursting causing fires, personal injury and damage. It will also void the Makita warranty for the Makita tool and charger.

**NOTICE:** Makita is not responsible for any accidents resulting from the use of non-genuine Makita batteries or batteries that have been modified. Genuine Makita batteries have been rigorously evaluated for compatibility with Makita tools and chargers, in line with applicable legislation and safety standards.

## Tips for maintaining maximum battery life

1. Charge the battery cartridge before completely discharged. Always stop tool operation and charge the battery cartridge when you notice

less tool power.

2. Never recharge a fully charged battery cartridge. Overcharging shortens the battery service life.
3. Charge the battery cartridge with room temperature at 10 °C - 40 °C (50 °F - 104 °F). Let a hot battery cartridge cool down before charging it.
4. When not using the battery cartridge, remove it from the tool or the charger.
5. Charge the battery cartridge if you do not use it for a long period (more than six months).

## FUNCTIONAL DESCRIPTION

**CAUTION:** Always be sure that the tool is switched off and the battery cartridge is removed before adjusting or checking function on the tool.

### Installing or removing battery cartridge

**CAUTION:** Always switch off the tool before installing or removing of the battery cartridge.

**CAUTION:** Hold the tool and the battery cartridge firmly when installing or removing battery cartridge. Failure to hold the tool and the battery cartridge firmly may cause them to slip off your hands and result in damage to the tool and battery cartridge and a personal injury.

To install the battery cartridge, align the tongue on the battery cartridge with the groove in the housing and slip it into place. Insert it all the way until it locks in place with a little click. If you can see the red indicator as shown in the figure, it is not locked completely.

To remove the battery cartridge, slide it from the tool while sliding the button on the front of the cartridge.

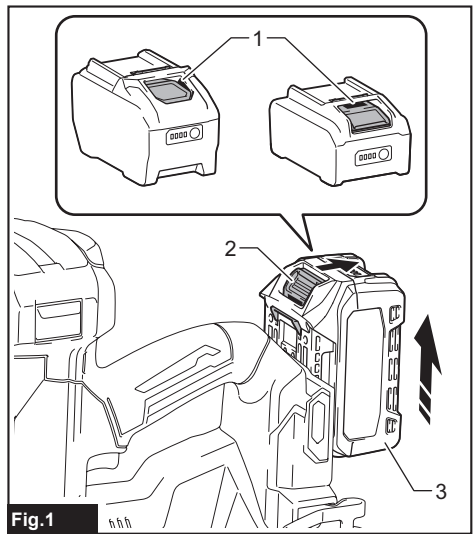

Fig.1

- 1. Red indicator 2. Button 3. Battery cartridge

**CAUTION:** Always install the battery cartridge fully until the red indicator cannot be seen. If not, it may accidentally fall out of the tool, causing injury to you or someone around you.

**CAUTION:** Do not install the battery cartridge forcibly. If the cartridge does not slide in easily, it is not being inserted correctly.

### Indicating the remaining battery capacity

Press the check button on the battery cartridge to indicate the remaining battery capacity. The indicator lamps light up for a few seconds.

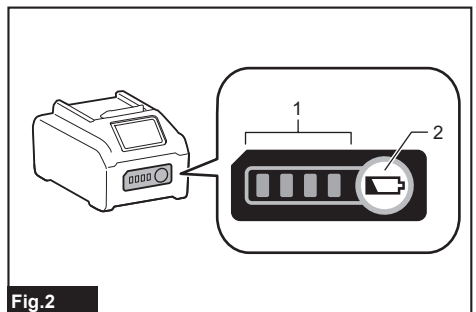





Fig.2

- 1. Indicator lamps 2. Check button

Indicator lamps			Remaining capacity
			
Lighted	Off	Blinking	
			75% to 100%

Indicator lamps			Remaining capacity
Lighted	Off	Blinking	
■	□	▧	50% to 75%
■ ■ ■ □	□ □ □ □		
■ ■ ■ □	□ □ □ □		25% to 50%
■ □ □ □	□ □ □ □		0% to 25%
▧ □ □ □	□ □ □ □		Charge the battery.
■ ■ □ □	□ □ □ □		The battery may have malfunctioned.
□ □ ■ ■	□ □ □ □		

**NOTE:** Depending on the conditions of use and the ambient temperature, the indication may differ slightly from the actual capacity.

**NOTE:** The first (far left) indicator lamp will blink when the battery protection system works.

## Tool / battery protection system

The tool is equipped with a tool/battery protection system. This system automatically cuts off power to the motor to extend tool and battery life. The tool will automatically stop during operation if the tool or battery is placed under one of the following conditions.

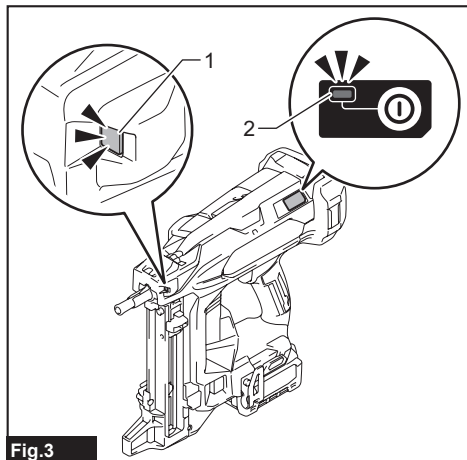

Fig.3

► 1. Lamp 2. Power indicator

## Protection status indication

Lamp		Power indicator		Status
On	Blinking	On	Blinking	
■	▧	■	▧	Overload
▧		▧		Overheat

## Overload protection

When the tool/battery is operated in a manner that causes it to draw an abnormally high current, the tool automatically stops. In this situation, turn the tool off and stop the application that caused the tool to become overloaded. Then turn the tool on to restart.

## Overheat protection

When the tool/battery is overheated, the tool stops automatically. In this situation, let the tool cool down before turning the tool on again.

## Overdischarge protection

When the battery capacity becomes low, the tool stops automatically. If the product does not operate even when the switches are operated, remove the battery(ies) from the tool and charge the battery(ies).

## Protections against other causes

Protection system is also designed for other causes that could damage the tool and allows the tool to stop automatically. Take all the following steps to clear the causes, when the tool has been brought to a temporary halt or stop in operation.

1. Make sure that all switch(es) is/are in the off position, and then turn the tool on again to restart.
2. Charge the battery(ies) or replace it/them with recharged battery(ies).
3. Let the tool and battery(ies) cool down.

If no improvement can be found by restoring protection system, then contact your local Makita Service Center.

## Power switch action

**CAUTION:** Before installing the battery cartridge into the tool, always check to see that the switch trigger actuates properly and returns to the "OFF" position when released.

To turn on the tool, press and hold the main power button until the power indicator lights up. To turn off the tool, press and hold the main power button until the power indicator goes off.

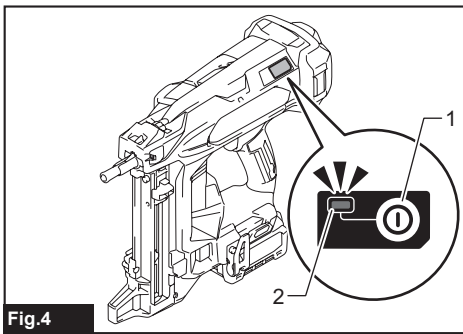

Fig.4

- 1. Main power button 2. Power indicator

**NOTE:** The tool cannot be turned on while either the switch trigger or the contact element is actuated. Be sure to release the switch trigger and the contact element before turning on the tool.

**NOTE:** The tool cannot be turned off while driving fasteners.

**NOTE:** The main power switch will automatically shut down if the tool is left unattended for an extended duration.

## Adjusting the driving depth

**⚠WARNING:** Always make sure that your fingers are not placed on the switch trigger or the contact element and the battery cartridge is removed before adjusting the depth of driving.

Turn the depth adjuster to adjust the driving depth. The driving depth gets deeper as you turn the depth adjuster to A direction, shallower to B direction in the figure. The range of the driving depth adjustment is 4.5 mm.

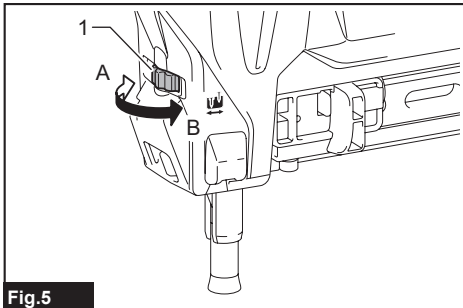

Fig.5

- 1. Depth adjuster

**NOTICE:** Do not turn the depth adjuster too much, or the depth adjuster may get stuck.

Adjust the driving depth as necessary.

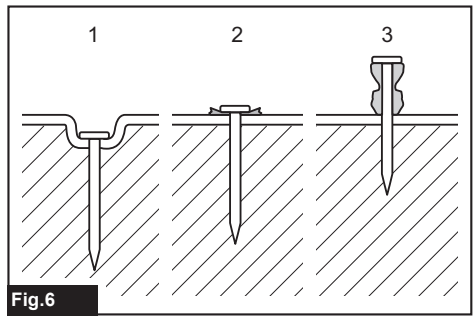

Fig.6

- 1. Too deep 2. Flush 3. Too shallow

## Lighting up the lamp

**⚠CAUTION:** Do not look in the light or see the source of light directly.

Pull the switch trigger or actuate the contact element to light up the lamp. The lamp keeps on lighting while pulling the switch trigger or actuating the contact element. The lamp goes out several seconds after releasing the switch trigger and the contact element.

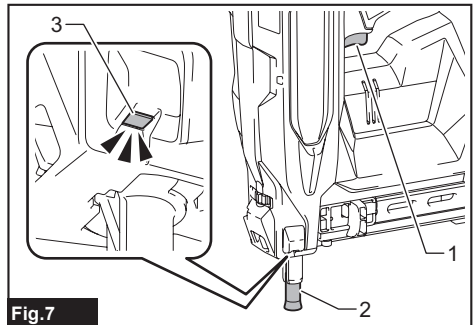

Fig.7

- 1. Switch trigger 2. Contact element 3. Lamp

**NOTICE:** Use a dry cloth to wipe the dirt off the lens of the lamp. Be careful not to scratch the lens of lamp, or it may lower the illumination.

**NOTICE:** When the tool is overheated, the lamp flashes. In this case, release the switch trigger and contact element, and then cool down the tool/battery before operating again.

**NOTE:** The tool may not fire after the battery becomes low on power even while the lamp remains lit. In this case, charge the battery cartridge.

## ASSEMBLY

**⚠CAUTION:** Always be sure that the tool is switched off and the battery cartridge is removed before carrying out any work on the tool.

## Loading/unloading the fasteners

**CAUTION:** Always make sure that the battery cartridge is removed before loading the fasteners. Unintentional firing may cause personal injuries and property damage.

**CAUTION:** Load the fasteners in the correct direction. Loading in wrong direction may cause premature wear and tear of the driver and damage of the other parts.

**CAUTION:** Be careful not to get your fingers caught in the magazine. The pusher tends to spring back to its original position unless you take the counteraction.

**CAUTION:** Do not abruptly slide the pusher with fasteners loaded in the magazine. Accidentally dropping fasteners especially when working in high places may cause personal injuries.

**NOTICE:** Gently slide the pusher along the magazine. A forceful contact between the pusher and fastener strip may damage the fasteners.

**NOTICE:** Make sure that the fastener strip is properly aligned in the magazine and secured with the pusher. If not, try reloading.

1. Remove the battery cartridge.
2. Insert a fastener strip into the slit of the magazine while you are pressing the unlock lever.

Make sure to align the outlines of the fastener heads with that of the slit.

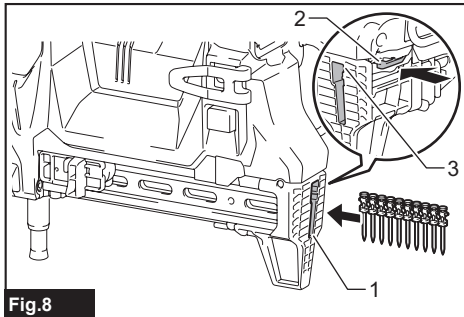

Fig. 8

- 1. Slit 2. Unlock lever 3. Fastener head outline

3. Pinch the pusher lever to raise the pusher plate up above the fastener strip loaded. Then pull the pusher towards the slit.

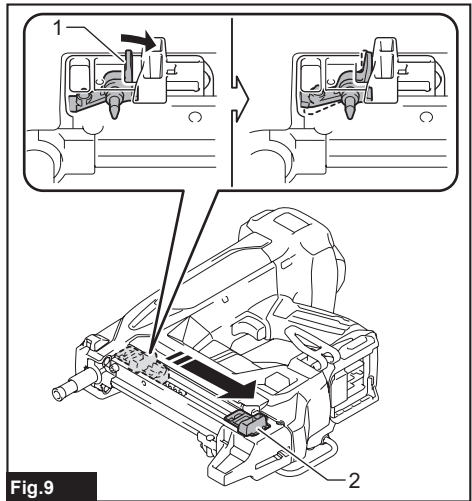

Fig. 9

- 1. Pusher lever 2. Pusher

4. Set the pusher lever free and slide the pusher back by releasing the spring tension safely.

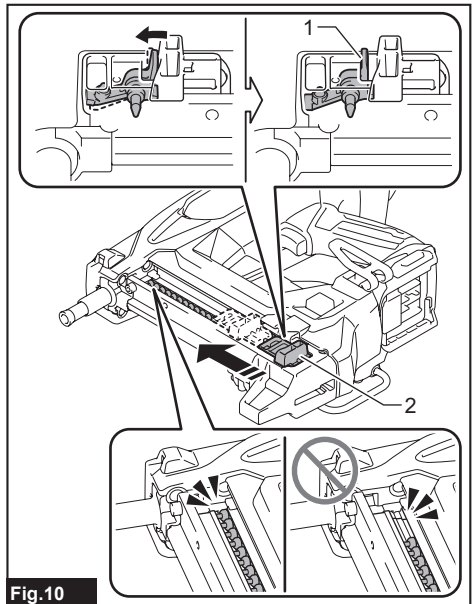

Fig. 10

- 1. Pusher lever 2. Pusher

**NOTICE:** Do not use deformed fasteners and fastener strips. Use fasteners specified in this manual. Using fasteners other than those specified may cause fastener jamming and malfunction.

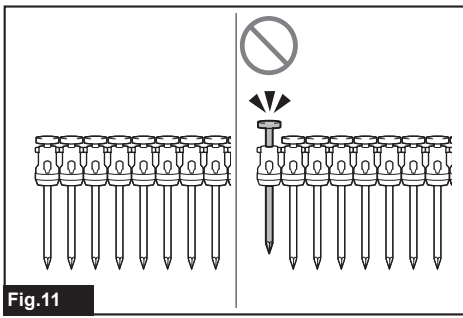

Fig.11

To remove fasteners, follow the steps below.

1. Pinch the pusher lever and slide the pusher back by releasing the spring tension safely.
2. Press the unlock lever to remove fasteners from the magazine.

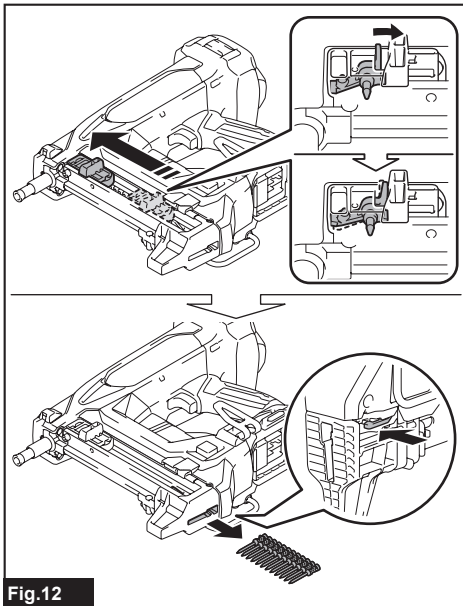

Fig.12

## Installing extended capacity magazine

### Optional accessory

**CAUTION:** Always make sure to unload all the fasteners left in the magazine and remove the battery cartridge from the tool before installing an extended capacity magazine.

Use a large-capacity magazine attachment so the tool carries more fasteners.

1. Remove all fasteners remaining in the magazine.
2. While you are pressing the unlock button, slide the magazine toward the front of the tool. Then remove the magazine by pulling it downward.

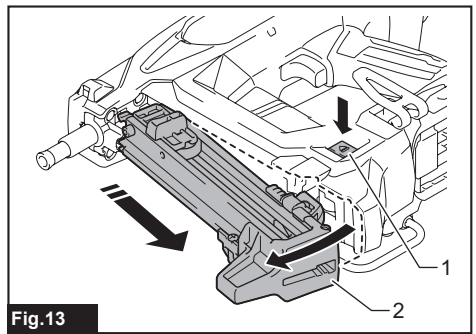

Fig.13

- ▶ 1. Unlock button 2. Magazine

3. Align the protrusion on the extended capacity magazine with the under driver guide groove, then insert the lock plate into the lock groove.

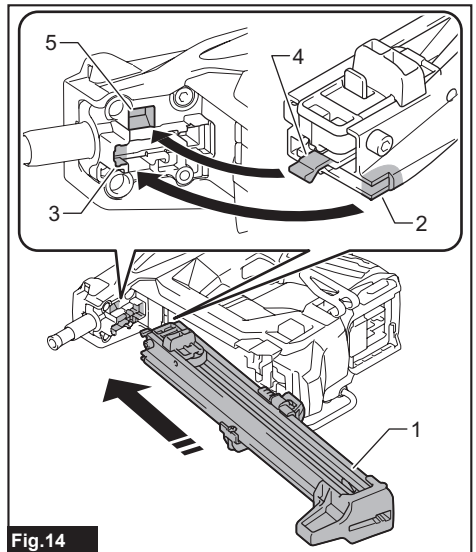
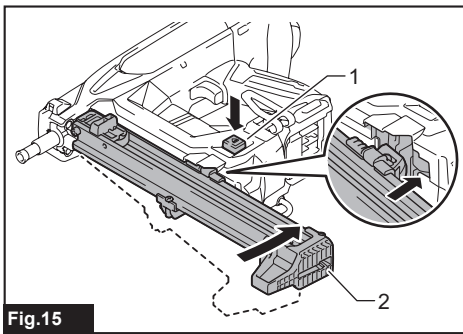

Fig.14

- ▶ 1. Extended capacity magazine 2. Protrusion 3. Under driver guide groove 4. Lock plate 5. Lock groove

4. Press and hold the unlock button, then slide the extended capacity magazine in the direction of the arrow in the figure.

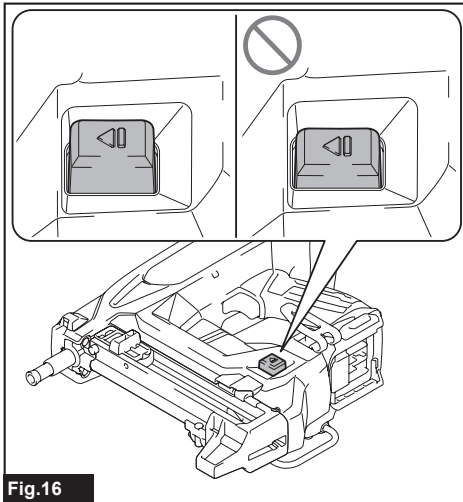

**Fig.15**

► 1. Unlock button 2. Extended capacity magazine

5. Release the unlock button, then push the extended capacity magazine into the tool.

**CAUTION:** After you install the magazines, make sure that the unlock button has returned to its original position. Failure to do so may cause the magazines to detach from the tool and result in personal injury.

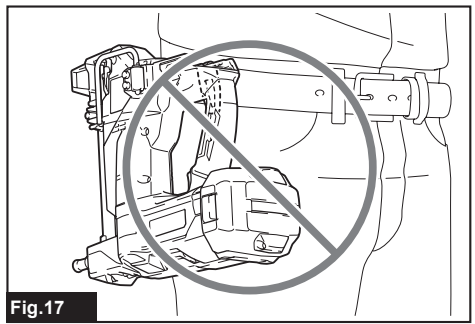

**Fig.16**

## Hook

**WARNING:** Be careful not to overload the hook with excessive force. Otherwise irregular overburden may cause damages to the tool resulting in personal injury.

**CAUTION:** Do not hang the hook from the waist belt. Dropping the tool, which is caused by the hook accidentally coming out of place, may cause unintentional firing and result in personal injuries.



**Fig.17**

**CAUTION:** When installing the hook, always secure it with the screw firmly. If not, the hook may come off from the tool and result in the personal injury.

**CAUTION:** Use the hanging/mounting parts for their intended purposes only. Using for unintended purpose may cause accident or personal injury.

**CAUTION:** Make sure to hang the tool securely before releasing your hold. Insufficient or unbalanced hooking may cause falling off and you may be injured.

Two types of tool hooks are available according to your needs. Use either a clip-shaped hook or C-shaped hook to hang the tool on a tool rack, rail or the wall.

### Clip-shaped hook

Insert the clip-shaped hook into a groove in the tool housing, and then secure it with a bolt.

To remove the clip-shaped hook, loosen the bolt and then take the hook out.

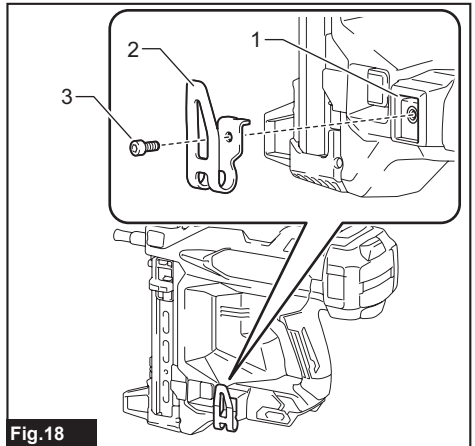

**Fig.18**

► 1. Groove 2. Clip-shaped hook 3. Bolt

### C-shaped hook

Aligning the two sets of bolt holes, place the C-shaped hook on the tool housing with the opening of the C-shaped hook faces upwards. Tighten the C-shaped hook with two bolts.

To remove the C-shaped hook, loosen the bolts and

then take the hook out.

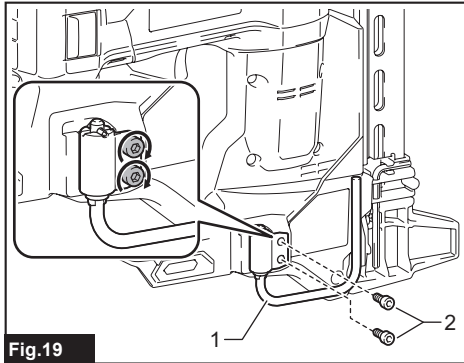

Fig.19

► 1. C-shaped hook 2. Bolt

The C-shaped hook can be positioned open at 90-degree intervals. Push and hold the hook upwards and swing it to your desired position.

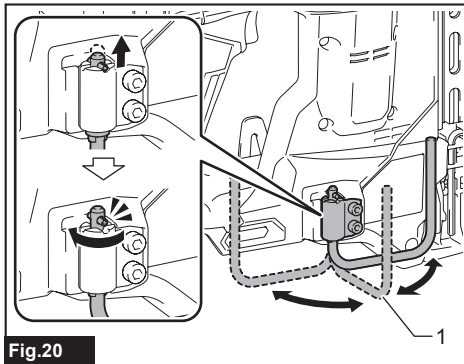

Fig.20

► 1. C-shaped hook

## Hex wrench storage

When not in use, store the hex wrench as shown in the figure to keep it from being lost.

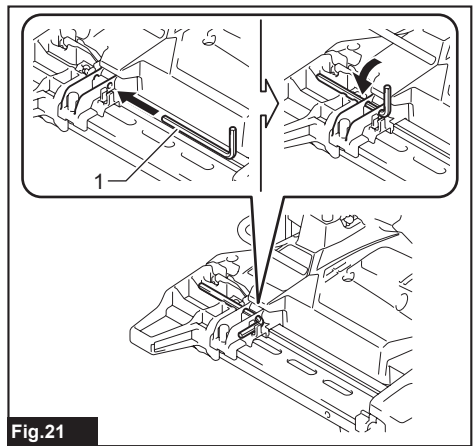

Fig.21

► 1. Hex wrench

## OPERATION

### Testing safety system

**⚠ WARNING:** Make sure all safety systems are in working order before operation. Failure to do so may cause personal injuries.

Test safety system as follows for possible fault or malfunction before operation.

1. Remove the battery cartridge from the tool. Then unload all the fasteners left in the magazine.
2. Install the battery cartridge in place and turn the tool on.
3. Pull the switch trigger without placing the contact element against the material.
4. Pull the pusher downward and hold it in place. Then place the contact element against the material without pulling the switch trigger.

If the tool works in case step 3 or 4 described above, safety system is not functioning properly. Stop using the tool immediately and ask your local Makita Service Center.

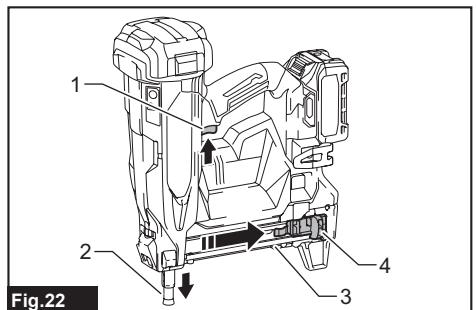

Fig.22

► 1. Switch trigger 2. Contact element 3. Magazine

## Handling of the fasteners

### Nails

Handle nails and their box carefully. If the nails have been handled roughly, they may be out of shape or their connector breaks, causing poor nail feed.

**NOTICE:** Avoid storing nails in a very humid or hot place or place exposed to direct sunlight.

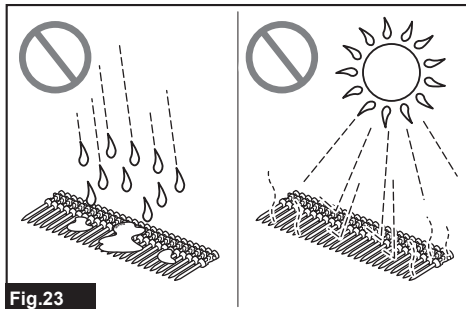

Fig.23

### Fastener penetration depth in concrete

**WARNING:** Only use hardened fasteners for concrete. Using other purposed fasteners may cause serious injury.

**WARNING:** Do not drive fasteners directly into the concrete. Failure to do so may cause concrete fragments to fly off or fasteners to rebound, resulting in serious injury.

**WARNING:** When you drive fasteners, hold the tool upright on the driving surface. Driving fasteners at a slanted angle may cause concrete fragments to fly off or fasteners to rebound, resulting in serious injury.

**WARNING:** Do not use the tool on surfaces that support suspended objects, such as areas where hangers for sewer pipes, ductwork, or similar equipment are mounted.

**CAUTION:** Before operation, perform a test firing. Depending on the combination of the hardness and the thickness of the concrete, the fastener penetration depth may be insufficient.

**CAUTION:** Avoid using this tool when a penetration depth of more than 20 mm is required. Fastening with insufficient penetration depth may cause the workpiece to become unstable, resulting in personal injury or property damage.

**CAUTION:** When you drive fasteners directly into hard surfaces such as steel, press the contact element firmly against the workpiece to prevent slipping.

Choose and use appropriate fasteners so that the

penetration depth into the concrete is between 15 mm and 20 mm.

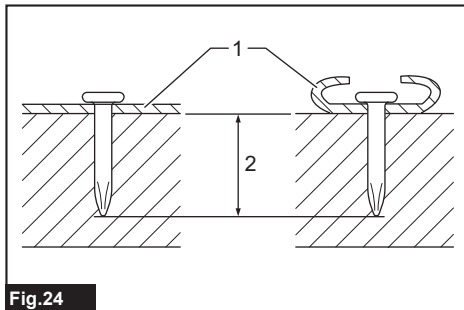

Fig.24

► 1. Thin steel plate 2. Penetration depth

## Driving fasteners

**WARNING:** Keep your face away from the tool when operating the tool. Failure to do so may cause injury.

**WARNING:** Do not use this tool for fastening electrical cables. This tool is not designed for electric cable installation and may damage the insulation of electric cables thereby causing electric shock or fire hazards.

**WARNING:** Continue to place the contact element firmly on the material until the fastener is driven completely. Unintentional firing may cause personal injuries.

**CAUTION:** Hold the tool firmly during operation.

**CAUTION:** Use only fasteners that are appropriate for the material. If the fastener is not appropriate for the material, the tool may kick back toward you and cause injury.

**NOTICE:** The tool will not start fastening after five seconds no switch operation while the contact element is placed on the workpiece. Pull the contact element free from the workpiece and reposition it in place to restart fastening.

**NOTE:** If you drive fasteners continuously for a long time, the exhaust air will get hot due to the heat from the motor.

A workpiece contact and then a trigger need to be activated in a specific sequence to actuate the tool. Release and re-activate the switch controls in the same sequence to continue driving fasteners.

**CAUTION:** Drive the fastener vertically into the material. Tilting the tool during operation may result in personal injury.

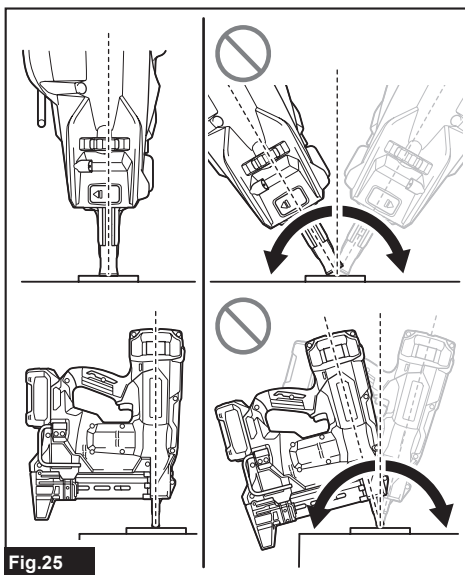

Fig.25

1. Press and hold the main power button to turn on the tool.
2. Place the contact element flat on the material.

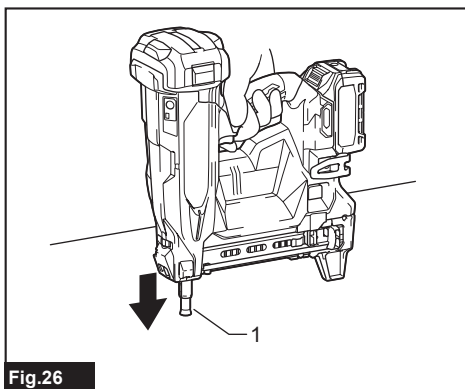

Fig.26

- ▶ 1. Contact element
3. Pull the switch trigger fully to drive a fastener.

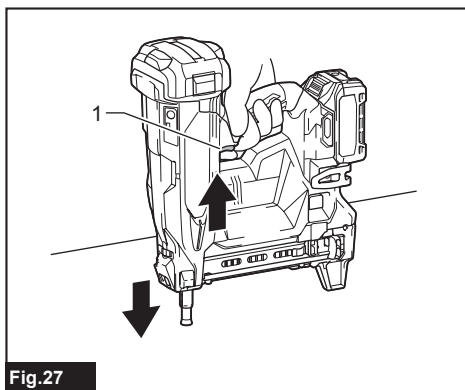

Fig.27

- ▶ 1. Switch trigger

4. Release your finger from the switch trigger. Then lift the contact element up from the material.

To drive the next fastener, repeat the steps 2 to 4 in the same sequence.

## Anti dry fire mechanism

When the remaining fasteners in the magazine decrease to 2 pieces, the switch can no longer be actuated and the tool stops firing. Insert a new strip of fasteners in the magazine before restarting operation.

## Removing jammed fasteners

**⚠WARNING:** Always make sure that the battery cartridge and fasteners are removed before removing jammed fasteners.

**⚠WARNING:** Do not push on the fastener driver forcibly. Do not strike the fastener driver and fasteners with any hand tools to clear jams. Mind that the tool is charged with compressed air and the pressure is maintained inside. Failure to follow the safety precautions in the manual can result in serious injury.

**⚠WARNING:** Never point the tool at yourself or other persons nearby when clearing jams. Failure to do so may cause a risk of injury by misfiring since the tool is charged with compressed air in a factory sealed chamber.

**⚠CAUTION:** Do not remove the jammed fasteners with bare hands. The fastener may jump out of the magazine and cause an injury.

**⚠CAUTION:** To address frequent jamming or hard-to-clear jamming situations, consult your local Makita Service Center.

When a fastener jamming occurs, look over closely the fastener feeding and driving unit. Jams tend to be caused by fasteners wedged between the driver and the driver guide.

1. Remove the battery cartridge from the tool.
2. Take out all the fasteners left in the magazine.
3. Clear a jam using pliers or the like.

**NOTE:** Dismount the contact element, the magazine, and the under driver guide from the tool if jamming occurs inside the fastener feeding and driving unit.

- Remove the contact element while you are sliding the lever.

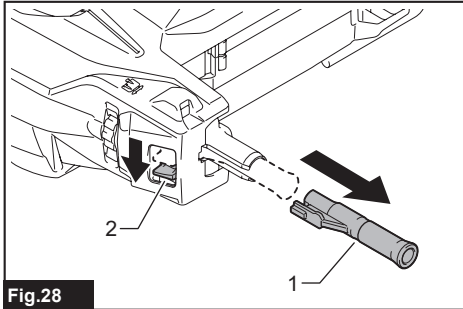

**Fig. 28**

- Contact element
- Lever

- While you are pressing the unlock button, slide the magazine toward the front of the tool. Then remove the magazine by pulling it downward.

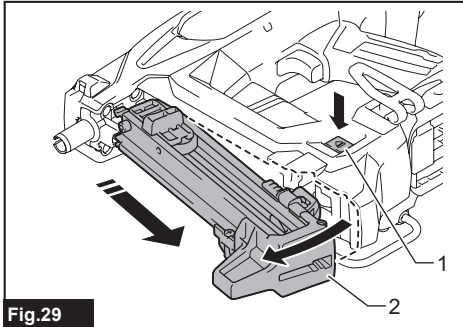

**Fig. 29**

- Unlock button
- Magazine

- Loosen and remove the bolts that secure the under driver guide using the hex wrench. Then, remove the under driver guide.

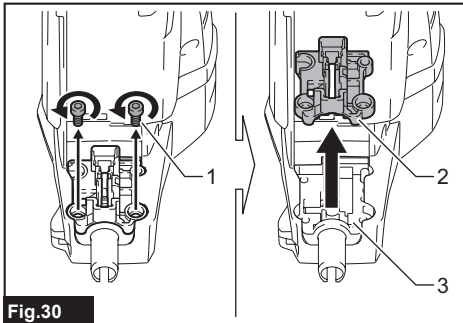

**Fig. 30**

- Bolt
- Under driver guide
- Driver guide

- Clear jammed fasteners in the fastener exit opening or the driver guide.

Use pliers to bend the jammed fastener so that the

fastener head comes out of the slot in the driver guide. Then remove the jammed fastener.

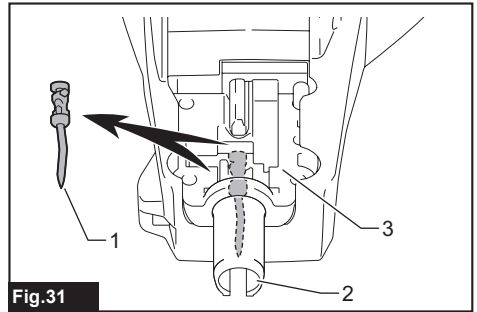

**Fig. 31**

- Jammed fastener
- Fastener exit opening
- Driver guide

A jamming may occur at the fastener feeding slot in the under driver guide. Use pliers to bend the jammed fastener so that the fastener head comes out of the slot in the under driver guide. Then remove the jammed fastener.

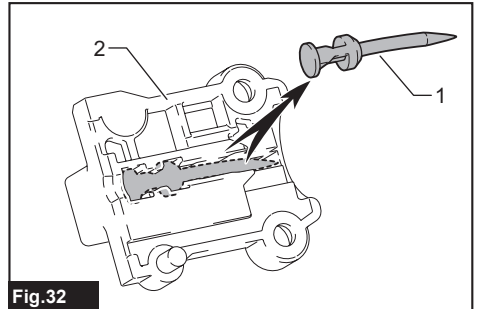

**Fig. 32**

- Jammed fastener
- Under driver guide

**NOTICE:** Make sure that there are no resin or metal fragments in the fastener exit opening, the driver guide, and the under driver guide. If resin or metal fragments remain, they may cause a fastener jam.

- To reassemble the contact element, the magazine, and the under driver guide, follow the removal procedures in reverse.

**CAUTION:** When you reassemble the under driver guide, tighten the bolt securely. Failure to do so may cause the bolt to loosen during operation and result in injury.

**CAUTION:** After reassembling the contact element and the magazine, make sure that both components are securely locked in place. Failure to do so may cause these components to come loose during operation and result in injury.

# MAINTENANCE

**⚠ WARNING:** Do not disassemble this tool. This tool is sealed with compressed air and disassembly may result in serious injury.



**⚠ CAUTION:** Always be sure that the tool is switched off and the battery cartridge is removed before attempting to perform inspection or maintenance.

**NOTICE:** Never use gasoline, benzine, thinner, alcohol or the like. Discoloration, deformation or cracks may result.

To maintain product SAFETY and RELIABILITY, repairs and any other maintenance or adjustment should be performed by Makita Authorized or Factory Service Centers, always using Makita replacement parts.

## Preventive maintenance

Thoroughly clean and inspect moving components (i.e., contact element, pusher, etc.) on a regular basis, keeping them free of dust and dirt that may accumulate over time.

**NOTE:** If the moving and sliding components as shown in the figure, seem to work poorly or inefficiently, blow any dirt and dust adhered around off and then wipe clean.

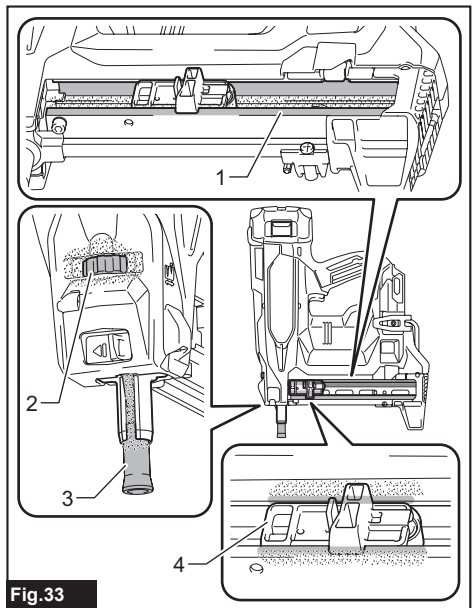

Fig.33

- ▶ 1. Feeding rails 2. Depth adjuster 3. Contact element 4. Pusher

## Initializing driver position

The driver may not be positioned correctly behind the fastener to be driven next after a fastener jamming or under low battery condition. Always perform initialization steps before you restart operation.

1. Remove the battery cartridge from the tool.
2. Take out all the fasteners left in the magazine.
3. Observe the driver position.

If you see the driver tip out of the driver guide when you remove the contact element, the contact element cannot correctly be actuated during initialization.

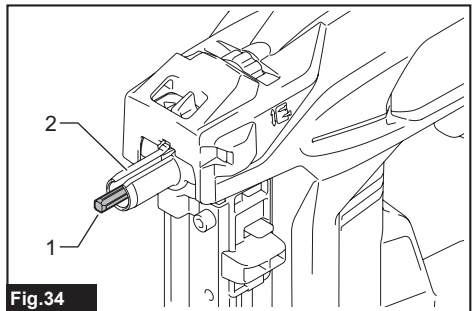

Fig.34

- ▶ 1. Driver 2. Driver guide

Reassemble the contact element and turn the depth adjuster to set the shallowest so that the contact element functions properly.

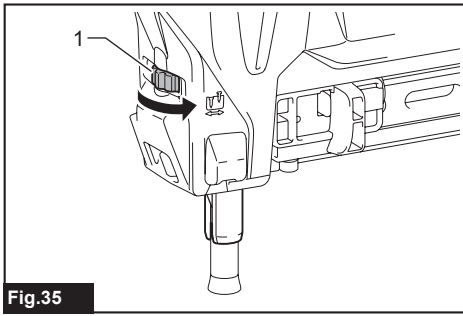

Fig.35

► 1. Depth adjuster

4. Install the battery cartridge in place and turn the tool on.
5. Pull the pusher downward and hold it in place. Then place the contact element against the material that can be damaged.
6. Pull the switch trigger fully, with the contact element actuated, to reset the driver position.

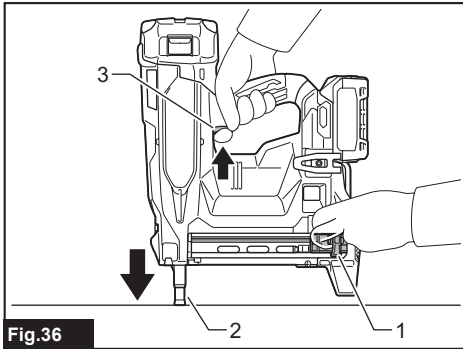

Fig.36

► 1. Pusher 2. Contact element 3. Switch trigger

The driver position will be initialized correctly.

7. Remove the battery cartridge from the tool. Reload the fasteners in the magazine. Place the battery cartridge back into the tool.

## OPTIONAL ACCESSORIES

**⚠ CAUTION:** These accessories or attachments are recommended for use with your Makita tool specified in this manual. The use of any other accessories or attachments might present a risk of injury. Only use an accessory or attachment for its stated purpose.

If you need any assistance for more details regarding these accessories, ask your local Makita Service Center.

- Nails
- Extended capacity magazines

- Makita genuine battery and charger

**NOTE:** Some items in the list may be included in the tool package as standard accessories. They may differ from country to country.



# Makita Europe N.V.

Jan-Baptist Vinkstraat 2, 3070 Kortenberg, Belgium

# Makita Corporation

3-11-8, Sumiyoshi-cho, Anjo, Aichi 446-8502 Japan

[www.makita.com](http://www.makita.com)



885B48-*** EN 20260422
------------------------------